

# Hardware Installation Guide

Product Model: DGS-3000 Series

Layer 2 Managed Gigabit Ethernet Switch

Release 1.10



---

Information in this document is subject to change without notice.

© 2014 D-Link Corporation. All rights reserved.

Reproduction in any manner whatsoever without the written permission of D-Link Corporation is strictly forbidden.

Trademarks used in this text: D-Link and the D-LINK logo are trademarks of D-Link Corporation; Microsoft and Windows are registered trademarks of Microsoft Corporation.

Other trademarks and trade names may be used in this document to refer to either the entities claiming the marks and names or their products. D-Link Corporation disclaims any proprietary interest in trademarks and trade names other than its own.

June, 2014 P/N 651GS3000035G

### **FCC Warning**

This equipment has been tested and found to comply with the limits for a Class A digital device, pursuant to Part 15 of the FCC Rules. These limits are designed to provide reasonable protection against harmful interference when the equipment is operated in a commercial environment. This equipment generates, uses, and can radiate radio frequency energy and, if not installed and used in accordance with this manual, may cause harmful interference to radio communications. Operation of this equipment in a residential area is likely to cause harmful interference in which case the user will be required to correct the interference at his own expense.

### **CE Mark Warning**

This is a Class A product. In a domestic environment, this product may cause radio interference in which case the user may be required to take adequate measures.

### **Warnung!**

Dies ist ein Produkt der Klasse A. Im Wohnbereich kann dieses Produkt Funkstörungen verursachen. In diesem Fall kann vom Benutzer verlangt werden, angemessene Massnahmen zu ergreifen.

### **Precaución!**

Este es un producto de Clase A. En un entorno doméstico, puede causar interferencias de radio, en cuyo caso, puede requerirse al usuario para que adopte las medidas adecuadas.

### **Attention!**

Ceci est un produit de classe A. Dans un environnement domestique, ce produit pourrait causer des interférences radio, auquel cas l'utilisateur devrait prendre les mesures adéquates.

### **Attenzione!**

Il presente prodotto appartiene alla classe A. Se utilizzato in ambiente domestico il prodotto può causare interferenze radio, nel cui caso è possibile che l'utente debba assumere provvedimenti adeguati.

### **VCCI Warning**

この装置は、クラス A 情報技術装置です。この装置を家庭環境で使用すると電波妨害を引き起こすことがあります。この場合には使用者が適切な対策を講ずるよう要求されることがあります。 VCCI-A

### **BSMI Notice**

警告使用者：

此為甲類的資訊技術設備，在居住環境中使用時，可能會造成射頻擾動，在這種情況下，使用者會被要求採取某些適當的對策。

# Table of Contents

Intended Readers .....	v
Typographical Conventions .....	v
Notes, Notices, and Cautions .....	v
Safety Instructions .....	vi
Safety Cautions .....	vi
General Precautions for Rack-Mountable Products .....	vii
Protecting Against Electrostatic Discharge.....	viii
<b>Chapter 1 Introduction.....</b>	<b>1</b>
Switch Description .....	1
Features .....	1
Ports.....	3
Front Panel Components.....	3
LED Indicators .....	5
Rear Panel Description.....	6
Side Panel Description .....	7
<b>Chapter 2 Installation.....</b>	<b>8</b>
Package Contents.....	8
Installation Guidelines.....	8
Installing the Switch without a Rack .....	9
Attaching Brackets to a Switch for Rack Mounting.....	9
Mounting the Switch in a Standard 19" Rack.....	10
Power On (AC Power) .....	10
Power Failure (AC Power).....	10
Connecting a DC Power Supply .....	10
Alarm Connector (DGS-3000-24TC/26TC Only) .....	11
Installing Power Cord Clip .....	13
Installing SFP and SFP+ Ports .....	16
Connecting the DPS-200 to the RPS Port.....	17
Installing the RPS into a Rack-mount Chassis .....	18
DPS-800 Rack-mount Chassis.....	18
DPS-900 Rack-mount Chassis.....	19
<b>Chapter 3 Connecting the Switch.....</b>	<b>21</b>
Switch to End Node .....	21
Switch to Switch.....	22
Connecting to Network Backbone or Server .....	23
<b>Chapter 4 Introduction to Switch Management .....</b>	<b>24</b>
Management Options .....	24
Connecting the Console Port.....	24
First Time Connecting to the Switch .....	26
Password Protection .....	26
IP Address Assignment .....	27
SNMP Settings.....	27
Traps.....	28
MIBs.....	28
<b>Chapter 5 Web-based Switch Configuration .....</b>	<b>29</b>
Introduction .....	29
Logging onto the Web Manager .....	29
Web-based User Interface.....	30
Areas of the User Interface.....	30

Web Pages .....	31
<b>Appendix Section .....</b>	<b>32</b>
Appendix A – Technical Specifications.....	32
General .....	32
Physical and Environmental .....	32
Performance .....	33
LED Indicators .....	33
Port Functions.....	35
Appendix B – Cables and Connectors.....	37
Ethernet Cable.....	37
Console Cable .....	38
Redundant Power Supply (RPS) Cable .....	39
<b>Warranties &amp; Technical Support.....</b>	<b>40</b>

# Intended Readers

**Typographical Conventions**  
**Notes, Notices, and Cautions**  
**Safety Instructions**  
**General Precautions**  
**Electrostatic Discharge**

The **DGS-3000 Series Hardware Installation Guide** contains information for set up and management of the Switch. This manual is intended for network managers familiar with network management concepts and terminology. For practical reasons all switches within this series will be simply referred to as the Switch throughout this manual. All example screenshots are taken from the **DGS-3000-26TC** Switch.

## Typographical Conventions

Convention	Description
[ ]	In a command line, square brackets indicate an optional entry. For example: [copy filename] means that optionally you can type copy followed by the name of the file. Do not type the brackets.
<b>Bold font</b>	Indicates a button, a toolbar icon, menu, or menu item. For example: Open the <b>File</b> menu and choose <b>Cancel</b> . Used for emphasis. May also indicate system messages or prompts appearing on screen. For example: <b>You have mail</b> . <b>Bold</b> font is also used to represent filenames, program names and commands. For example: <b>use the copy command</b> .
Boldface Typewriter Font	Indicates commands and responses to prompts that must be typed exactly as printed in the manual.
Initial capital letter	Indicates a window name. Names of keys on the keyboard have initial capitals. For example: Click Enter.
<b>Menu Name &gt; Menu Option</b>	<b>Menu Name &gt; Menu Option</b> Indicates the menu structure. <b>Device &gt; Port &gt; Port Properties</b> means the Port Properties menu option under the Port menu option that is located under the Device menu.

## Notes, Notices, and Cautions



A **NOTE** indicates important information that helps make better use of the device.



A **NOTICE** indicates either potential damage to hardware or loss of data and tells how to avoid the problem.



A **CAUTION** indicates a potential for property damage, personal injury, or death.

# Safety Instructions

Use the following safety guidelines to ensure your own personal safety and to help protect your system from potential damage. Throughout this safety section, the caution icon () is used to indicate cautions and precautions that need to be reviewed and followed.

## Safety Cautions

To reduce the risk of bodily injury, electrical shock, fire, and damage to the equipment, observe the following precautions.

- Observe and follow service markings.
  - Do not service any product except as explained in the system documentation.
  - Opening or removing covers that are marked with the triangular symbol with a lightning bolt may expose the user to electrical shock.
  - Only a trained service technician should service components inside these compartments.
- If any of the following conditions occur, unplug the product from the electrical outlet and replace the part or contact your trained service provider:
  - Damage to the power cable, extension cable, or plug.
  - An object has fallen into the product.
  - The product has been exposed to water.
  - The product has been dropped or damaged.
  - The product does not operate correctly when the operating instructions are correctly followed.
- Keep your system away from radiators and heat sources. Also, do not block cooling vents.
- Do not push any objects into the openings of the system. Doing so can cause fire or electric shock by shorting out interior components.
- Use the product only with approved equipment.
- Allow the product to cool before removing covers or touching internal components.
- Operate the product only from the type of external power source indicated on the electrical ratings label. If unsure of the type of power source required, consult your service provider or local power company.
- To help avoid damaging the system, be sure the voltage selection switch (if provided) on the power supply is set to match the power available at the Switch's location:
  - 115 volts (V)/60 hertz (Hz) in most of North and South America and some Far Eastern countries such as South Korea and Taiwan
  - 100 V/50 Hz in eastern Japan and 100 V/60 Hz in western Japan
  - 230 V/50 Hz in most of Europe, the Middle East, and the Far East
- Also, be sure that attached devices are electrically rated to operate with the power available in your location.
- Use only approved power cable(s). If you have not been provided with a power cable for your system or for any AC-powered option intended for your system, purchase a power cable that is approved for use in your country. The power cable must be rated for the product and for the voltage and current marked on the product's electrical ratings label. The voltage and current rating of the cable should be greater than the ratings marked on the product.
- To help prevent electric shock, plug the system and peripheral power cables into properly grounded electrical outlets. These cables are equipped with three-prong plugs to help ensure proper grounding. Do not use adapter plugs or remove the grounding prong from a cable. If using an extension cable is necessary, use a 3-wire cable with properly grounded plugs.
- Observe extension cable and power strip ratings. Make sure that the total ampere rating of all products plugged into the extension cable or power strip does not exceed 80 percent of the ampere ratings limit for the extension cable or power strip.
- To help protect the system from sudden, transient increases and decreases in electrical power, use a surge suppressor, line conditioner, or uninterruptible power supply (UPS).
- Position system cables and power cables carefully; route cables so that they cannot be stepped on or tripped over. Be sure that nothing rests on any cables.

- Do not modify power cables or plugs. Consult a licensed electrician or your power company for site modifications. Always follow your local/national wiring rules.
- When connecting or disconnecting power to hot-pluggable power supplies, if offered with your system, observe the following guidelines:
  - Install the power supply before connecting the power cable to the power supply.
  - Unplug the power cable before removing the power supply.
  - If the system has multiple sources of power, disconnect power from the system by unplugging all power cables from the power supplies.
  - Move products with care; ensure that all casters and/or stabilizers are firmly connected to the system. Avoid sudden stops and uneven surfaces.

## General Precautions for Rack-Mountable Products

Observe the following precautions for rack stability and safety. Also, refer to the rack installation documentation accompanying the system and the rack for specific caution statements and procedures.

Systems are considered to be components in a rack. Thus, "component" refers to any system as well as to various peripherals or supporting hardware.



**CAUTION:** Installing systems in a rack without the front and side stabilizers installed could cause the rack to tip over, potentially resulting in bodily injury under certain circumstances. Therefore, always install the stabilizers before installing components in the rack. After installing system/components in a rack, never pull more than one component out of the rack on its slide assemblies at one time. The weight of more than one extended component could cause the rack to tip over and may result in serious injury.

- Before working on the rack, make sure that the stabilizers are secured to the rack, extended to the floor, and that the full weight of the rack rests on the floor. Install front and side stabilizers on a single rack or front stabilizers for joined multiple racks before working on the rack.
- Always load the rack from the bottom up, and load the heaviest item in the rack first.
- Make sure that the rack is level and stable before extending a component from the rack.
- Use caution when pressing the component rail release latches and sliding a component into or out of a rack; the slide rails can pinch your fingers.
- After a component is inserted into the rack, carefully extend the rail into a locking position, and then slide the component into the rack.
- Do not overload the AC supply branch circuit that provides power to the rack. The total rack load should not exceed 80 percent of the branch circuit rating.
- Ensure that proper airflow is provided to components in the rack.
- Do not step on or stand on any component when servicing other components in a rack.



**NOTE:** A qualified electrician must perform all connections to DC power and to safety grounds. All electrical wiring must comply with applicable local, regional or national codes and practices.



**CAUTION:** Never defeat the ground conductor or operate the equipment in the absence of a suitably installed ground conductor. Contact the appropriate electrical inspection authority or an electrician if uncertain that suitable grounding is available.



**CAUTION:** The system chassis must be positively grounded to the rack cabinet frame. Do not attempt to connect power to the system until grounding cables are connected. Completed power and safety ground wiring must be inspected by a qualified electrical inspector. An energy hazard will exist if the safety ground cable is omitted or disconnected.

# Protecting Against Electrostatic Discharge

Static electricity can harm delicate components inside the system. To prevent static damage, discharge static electricity from your body before touching any of the electronic components, such as the microprocessor. This can be done by periodically touching an unpainted metal surface on the chassis.

The following steps can also be taken prevent damage from electrostatic discharge (ESD):

1. When unpacking a static-sensitive component from its shipping carton, do not remove the component from the antistatic packing material until ready to install the component in the system. Just before unwrapping the antistatic packaging, be sure to discharge static electricity from your body.
2. When transporting a sensitive component, first place it in an antistatic container or packaging.
3. Handle all sensitive components in a static-safe area. If possible, use antistatic floor pads, workbench pads and an antistatic grounding strap.



# Chapter 1 Introduction

## *Switch Description*

### *Features*

### *Ports*

### *Front Panel Components*

### *LED Indicators*

### *Rear Panel Description*

### *Side Panel Description*

## Switch Description

The DGS-3000 Series is part of the Layer 2 family of D-Link's managed switch product line. The switches provide wired Gigabit speed access for metro and campus networks. The two embedded 10G SFP+ ports on the DGS-3000-26TC guarantee performance during aggregation of numerous Gigabit connections.

The DGS-3000 Series is designed as a 1U rackmount case suitable for desktops and telecom cabinets. The DGS-3000-10TC is more compact, using a 9-inch case that comfortably fits in telecom distribution boxes. The smaller dimensions provide better air flow in limited spaces and also make cable management easier.

The embedded alarm port of DGS-3000-24TC and the DGS-3000-26TC allows for input of external sensors to detect potential threats such as open doors or cabinet overheating which then trigger warning events. This is extremely useful for a device that may be widely deployed in any metropolitan environment.

The Series features the following list of switches:

- **DGS-3000-10TC:** 8-Port 10/100/1000 Base-T + 2 Combo 10/100/1000BASE-T/SFP ports, L2 Management Switch.
- **DGS-3000-24TC:** 20-Port 10/100/1000 Base-T + 4 Combo 10/100/1000BASE-T/SFP ports, L2 Management Switch.
- **DGS-3000-26TC:** 20-Port 10/100/1000 Base-T + 4 Combo 10/100/1000BASE-T/SFP ports + 2-Port 10G SFP+, L2 Management Switch.

## Features

The list below highlights the significant protocols and features supported by the Switch.

- IEEE 802.3 Ethernet Working Group
- IEEE 802.3z Gigabit Ethernet transmission over Fiber for LAN
- IEEE 802.3x Flow Control in full-duplex compliant
- IEEE 802.3u Fast Ethernet with Auto-negotiation
- IEEE 802.3ab Gigabit Ethernet transmission over Unshielded Twisted Pair (UTP)
- IEEE 802.3ae 10 Gigabit Ethernet transmission over Fiber for LAN
- IEEE 802.3aq 10 Gigabit Ethernet transmission over Multimode Fiber with Enhanced Equalization
- IEEE 802.3az Energy-Efficient Ethernet
- IEEE 802.1p Priority Queues
- IEEE 802.3ad Link Aggregation Control Protocol
- IEEE 802.1X Port-based and Host-based Access Control
- IEEE 802.1Q VLAN
- IEEE 802.1D Spanning Tree
- IEEE 802.1w Rapid Spanning Tree
- IEEE 802.1s Multiple Spanning Tree support
- Jumbo frame to 12K Bytes
- Access Control List
- ISM VLAN
- DHCP local relay

- Single IP Management
- Access Authentication Control utilizing TACACS, XTACACS, TACACS+, and RADIUS protocols
- Compound Authentication
- Power saving mode
- Simple Network Time Protocol (SNTP)
- System Log
- Full- and half-duplex for all ports. Full duplex allows the switch port to simultaneously transmit and receive data. It only works with connections to full-duplex-capable end stations and switches. Connections to a hub must take place at half-duplex.
- Unicast, broadcast, and multicast storm control
- Loopback Detection (LBD)
- Efficient self-learning and address recognition mechanism enables forwarding rate at wire speed
- Address table: up to 16 K
- Packet buffer memory of up to 1.5 MByte
- VLAN Trunking
- Private VLAN
- 802.1Q (2005 edition)
- GVRP
- Voice VLAN by MAC address
- VLAN tagging based on PVID
- IGMP Snooping v1, v2 and v3 awareness
- MLD Snooping v1 and v2 awareness
- SNMP v1/v2/v3
- SNMP over IPv6
- Secure Sockets Layer (SSL) v1/v2/v3
- Secure Shell (SSH) v2
- Port Mirroring
- LLDP
- NLB
- Traffic segmentation
- D-Link Safeguard Engine
- Japanese Web-based Access Control (JWAC)
- MAC-based Access Control (MAC)
- Guest VLAN
- Microsoft® NAP--IPv4 and IPv6, 802.1X NAP, and DHCP NAP
- Database Failover
- RADIUS accounting
- RADIUS authentication for management access
- TACACS+ authentication for management access
- User account privilege for management access—four levels of user accounts
- DHCP server screening
- ARP spoofing prevention
- MIB support for:
  - RFC 1213 MIB II
  - RFC 4188 Bridge MIB
  - RFC 1907 SNMPv2 MIB
  - RFC 2819 RMON MIB
  - RFC 2021 RMONv2 MIB
  - RFC 2571 SNMP MIB, RFC 2572 SNMP MIB, RFC 2573 SNMP MIB
  - RFC 2574 SNMPv3 MIB

- RFC 2575 VACM for SNMP MIB
  - RFC 2576 SNMPv1, v2 & v3 MIB
  - RFC 2665 Ether-like MIB
  - RFC 4363 P-Bridge MIB and Q-Bridge MIB
  - RFC 2863 IF MIB
  - RFC 2618 RADIUS Authentication Client MIB
  - RFC 2620 RADIUS Accounting Client MIB
  - RFC 2925 Ping and Traceroute MIB
  - Private MIB
  - RFC 4293 IPv6 MIB
  - RFC 4022 TCP MIB
  - LLDP MIB
  - LLDP-DOT1-MIB, LLDP-DOT3-MIB
- Provides parallel LED display for port status such as link/act, speed, etc.
  - Web-based GUI compatible with most major browsers, including Internet Explorer (version 5.5 and later), Mozilla Firefox (version 2.0 and later), Safari (version 4.0 and later), and Google Chrome (version 6.0 and later).

## Ports

<b>DGS-3000-10TC</b>	Eight Copper ports (10/100/1000Mbps). Two Combo Copper/SFP ports (10/100/1000Mbps and 100/1000Mbps).
<b>DGS-3000-24TC</b>	Twenty Copper ports (10/100/1000Mbps). Four Combo Copper/SFP ports (10/100/1000Mbps and 100/1000Mbps).
<b>DGS-3000-26TC</b>	Twenty Copper ports (10/100/1000Mbps). Four Combo Copper/SFP ports (10/100/1000Mbps and 100/1000Mbps). Two SFP+ ports (1000Mbps/10Gbps).

- All the switches are equipt with one RJ-45 Console port (a special console cable with a DB9 interface is provided to connect the Switch to a PC)



**NOTE:** For customers interested in D-View, D-Link Corporation's proprietary SNMP management software, go to <http://dview.dlink.com.tw/> and download the software and manual.

## Front Panel Components

The front panel of the Switch consists of LED indicators for Power, Console, RPS, Fan Err, and for Link/Act for each port on the Switch including SFP port LEDs. DGS-3000-26TC has an alarm port at the front panel.

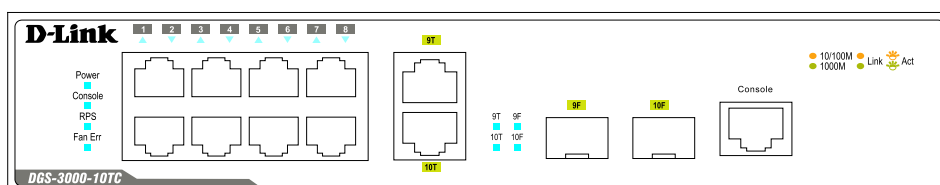

Figure 1-1 Front panel view of the DGS-3000-10TC

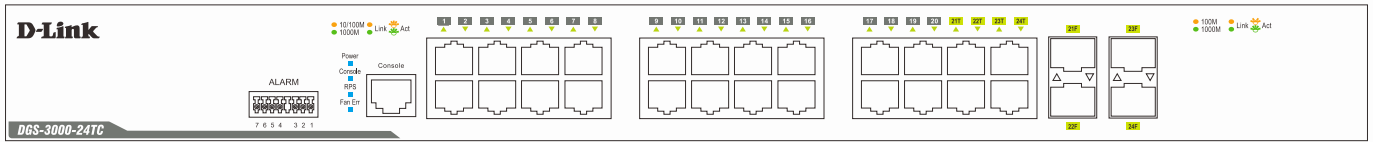

Figure 1-2 Front panel view of the DGS-3000-24TC

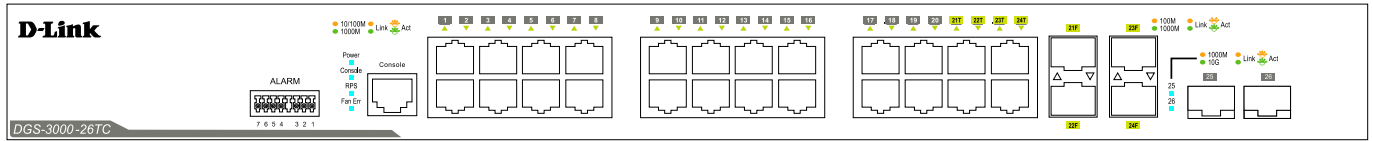

Figure 1-3 Front panel view of the DGS-3000-26TC

## LED Indicators

The Switch front panel presents LED indicators for Power, Console, RPS, Fan Err, and Link/Act indicators for all ports including the Gigabit Ethernet ports.

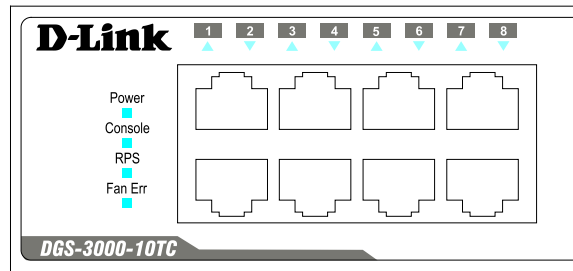

Figure 1-4 LED indicators for the DGS-3000-10TC

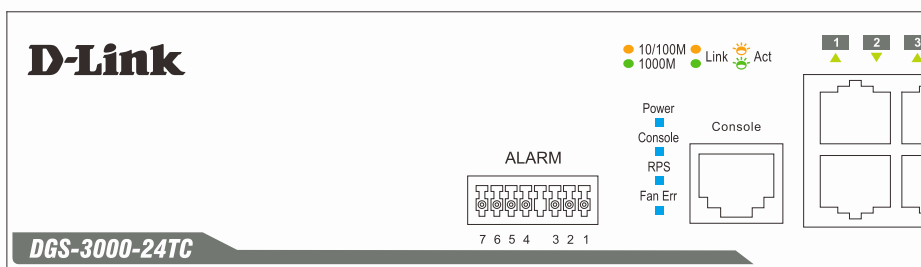

Figure 1-5 LED indicators for the DGS-3000-24TC

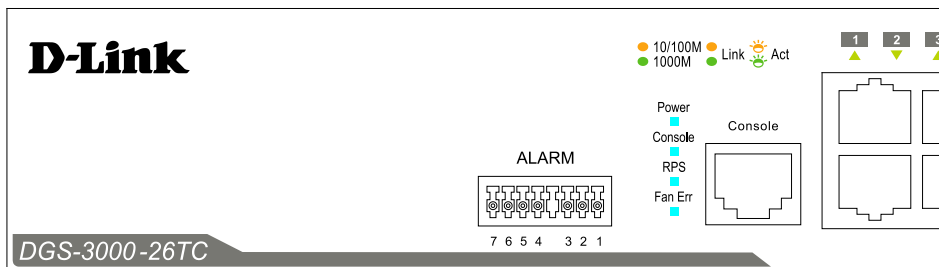
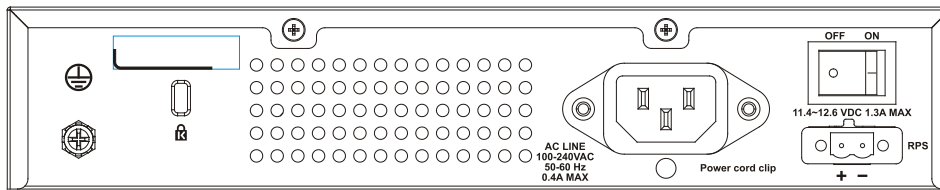

Figure 1-6 LED indicators for the DGS-3000-26TC

LED	Description
<b>Power</b>	This LED lights green after powering the Switch on to indicate the ready state of the device. The indicator is dark when the Switch is no longer receiving power (i.e. powered off).
<b>Console</b>	This LED blinks green during the Power-On Self Test (POST). When the POST is finished, the LED goes dark. The indicator lights steady green when a user is logged in through the console port.
<b>RPS</b>	This LED lights green if the Redundant Power Supply (RPS) is connected, the RPS switch is turned on. If the indicator is off, the RPS is not connected or the RPS switch is turned off.
<b>Fan Err</b>	This LED blinks red when any of the fans has failed. No light indicates all fans are working normally.
<b>Link/Act LEDs</b>	The Switch has LED indicators for Link and Activity.

## Rear Panel Description

The rear panel contains an AC power socket, an ON/OFF toggle switch, an outlet for an external redundant power supply or a DC power supply, and security lock.



**Figure 1-7 Rear panel view of the DGS-3000-10TC**

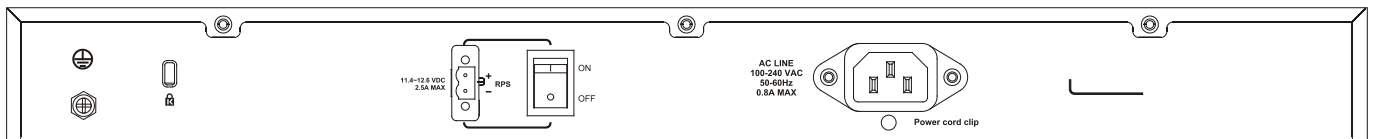

**Figure 1-8 Rear panel view of the DGS-3000-24TC**

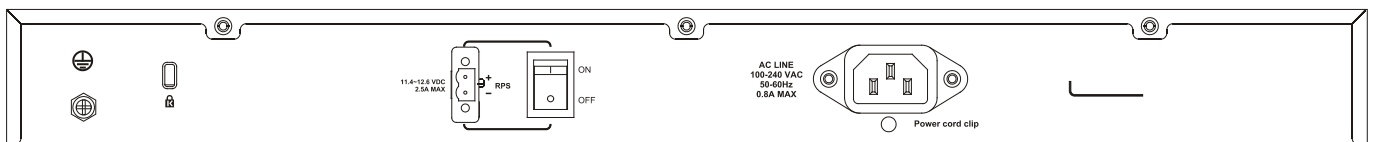
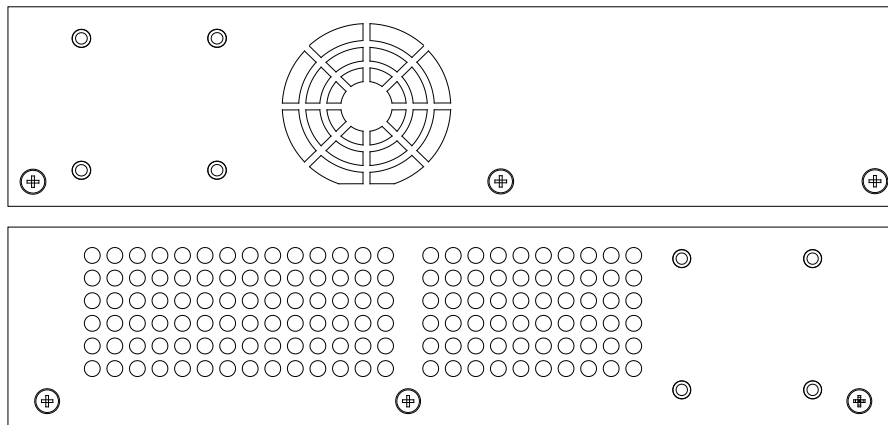

**Figure 1-9 Rear panel view of the DGS-3000-26TC**

The AC power socket is a standard three-pronged connector that supports the power cord. Plug-in the female connector of the provided power cord into this socket, and the male side of the cord into a power outlet. The Switch automatically adjusts the power setting to any supply voltage in the range from 100 to 240 VAC at 50 to 60 Hz. An optional external Redundant Power Supply (DPS-200) can be plugged into the RPS outlet displayed above. When the internal power fails, this optional external RPS will take over all the power immediately and automatically.

## Side Panel Description

The system heat vents located on each side dissipate heat. Do not block these openings. Leave at least 6 inches of space at the rear and sides of the Switch for proper ventilation. Be reminded that without proper heat dissipation and air circulation, system components might overheat, which could lead to system failure or even severely damage components.



**Figure 1-10 Identical side panels of the DGS-3000-10TC**

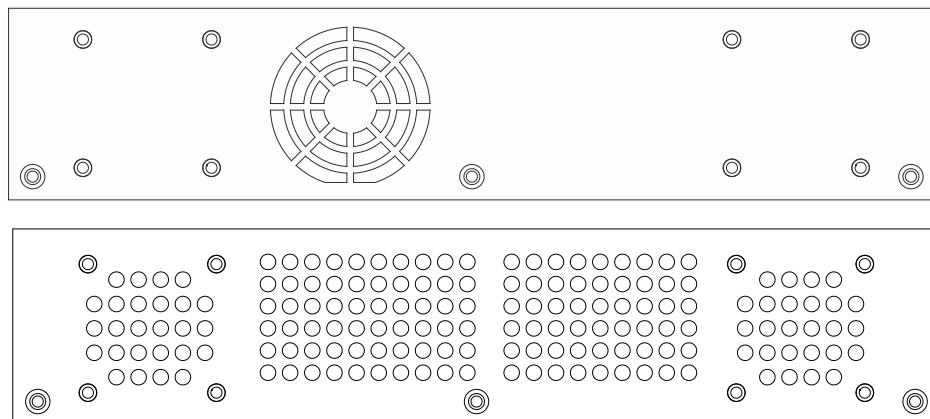

**Figure 1-11 Identical side panels of the DGS-3000-24TC**

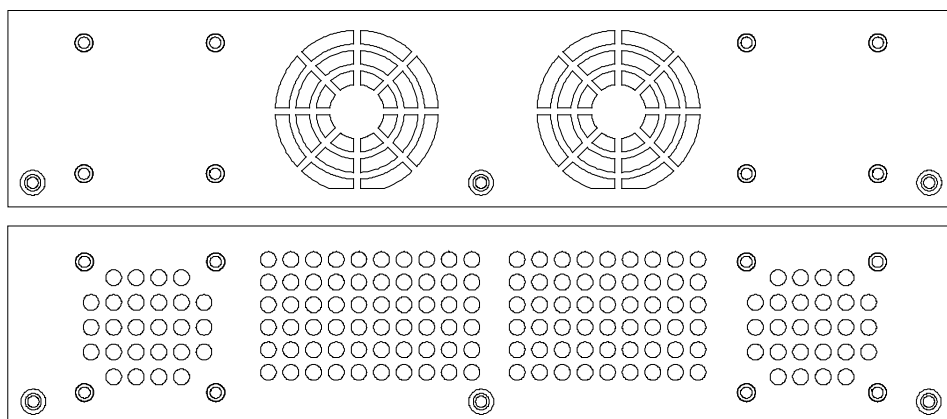

**Figure 1-12 Identical side panels of the DGS-3000-26TC**

## Chapter 2 Installation

### ***Package Contents***

### ***Installation Guidelines***

### ***Power On (AC Power)***

### ***Alarm Connector (DGS-3000-24TC/26TC Only)***

### ***Installing Power Cord Clip***

### ***Installing SFP and SFP+ Ports***

### ***Connecting the DPS-2000 to the RPS Port***

### ***Installing the RPS into a Rack-mount Chassis***

## Package Contents

Open the shipping carton of the Switch and carefully unpack its contents. The carton should contain the following items:

- One DGS-3000 Series Switch
- One Quick Installation Guide
- AC power cord(s)
- One DC power source connector
- One RJ-45 to RS-232 console
- One set of Power Cord Clip
- One mounting kit (two brackets and screws)
- Four rubber feet with adhesive backing
- One CD kit for Web UI Reference Guide, CLI Reference Guide, and D-View module

If any item is missing or damaged, please contact your local D-Link reseller for replacement.

## Installation Guidelines

Please follow these guidelines for setting up the Switch:

- Install the Switch on a sturdy, level surface that can support at least 13.9 lb. (6.3 kg) of weight. Do not place heavy objects on the Switch.
- The power outlet should be within 1.82 meters (6 feet) of the Switch.
- Visually inspect the power cord and see that it is fully secured to the AC power port.
- Make sure that there is proper heat dissipation from and adequate ventilation around the Switch. Leave at least 10 cm (4 inches) of space at the front and rear of the Switch for ventilation.
- Install the Switch in a fairly cool and dry place for the acceptable temperature and humidity operating ranges.
- Install the Switch in a site free from strong electromagnetic field generators (such as motors), vibration, dust, and direct exposure to sunlight.
- When installing the Switch on a level surface, attach the rubber feet to the bottom of the device. The rubber feet cushion the Switch, protect the casing from scratches and prevent it from scratching other surfaces.



## Installing the Switch without a Rack

First, attach the rubber feet included with the Switch if installing on a desktop or shelf. Attach these cushioning feet on the bottom at each corner of the device. Allow enough ventilation space between the Switch and any other objects in the vicinity.

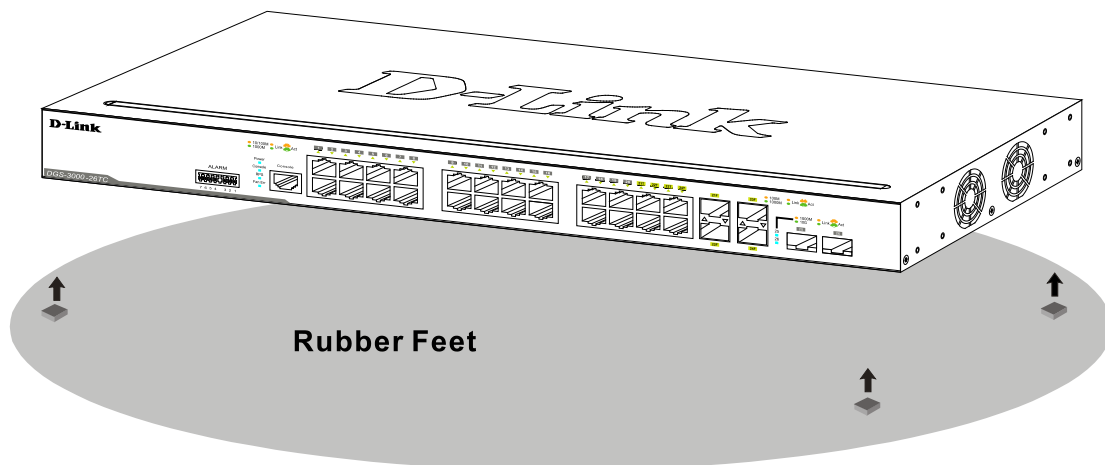

Figure 2-1 Prepare the Switch for installation on a desktop or shelf

## Attaching Brackets to a Switch for Rack Mounting

The Switch can be mounted in a standard 19" rack using the provided mounting brackets. Use the following diagrams as a guide.

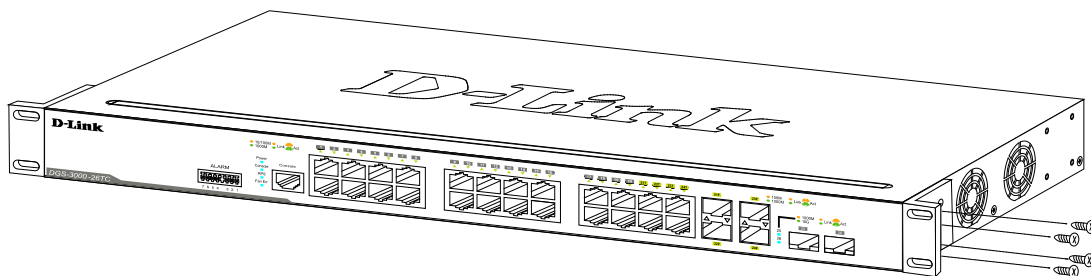

Figure 2-2 Fasten mounting brackets on the Switch

Fasten the mounting brackets to the Switch using the screws provided. With the brackets attached securely, the Switch can be mounted in a standard rack, as shown below.



**NOTE:** Please review the Installation Guidelines above before installing the Switch in a rack. Make sure there is adequate space around the Switch to allow for proper air flow, ventilation, and cooling.

## Mounting the Switch in a Standard 19" Rack

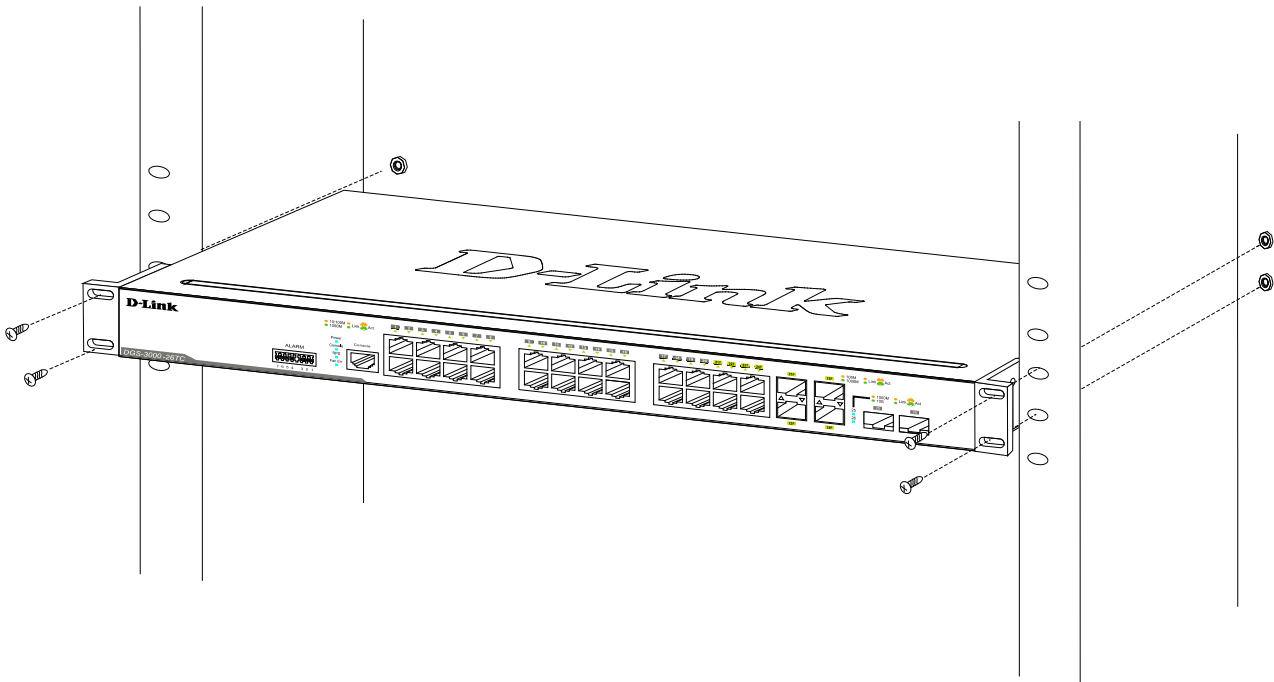

Figure 2-3 Installing the Switch in a rack

## Power On (AC Power)

1. Plug one end of the AC power cord into the power socket of the Switch and the other end into the local power source outlet.
2. After powering on the Switch, the LED indicators will momentarily blink green. This blinking of the LED indicators represents a reset of the system.

## Power Failure (AC Power)

For AC power supply units, as a precaution, in the event of a power failure, unplug the Switch. When power has resumed, plug the Switch back in.



**CAUTION:** Installing systems in a rack without the front and side stabilizers installed could cause the rack to tip over, potentially resulting in bodily injury under certain circumstances. Therefore, always install the stabilizers before installing components in the rack. After installing components in a rack, do not pull more than one component out of the rack on its slide assemblies at one time. The weight of more than one extended component could cause the rack to tip over and may result in injury.

## Connecting a DC Power Supply

The Switch provides a DC power source connector to connect to any DC power source. The DC power source must meet the following requirements:

- The DC power source's output voltage must be between 11.4V and 12.6V.
- The DC power source's output current rate must be higher or equal to 2.5A.
- Voltage protection must be applied when the voltage is higher or equal to 15V.
- Current protection must be applied when the current is higher or equal to 6A.

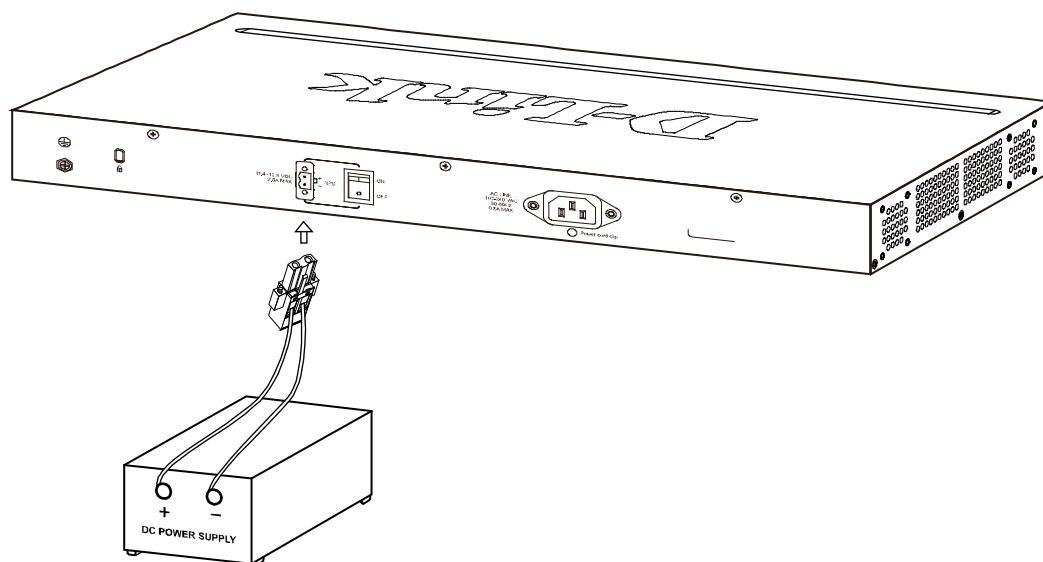
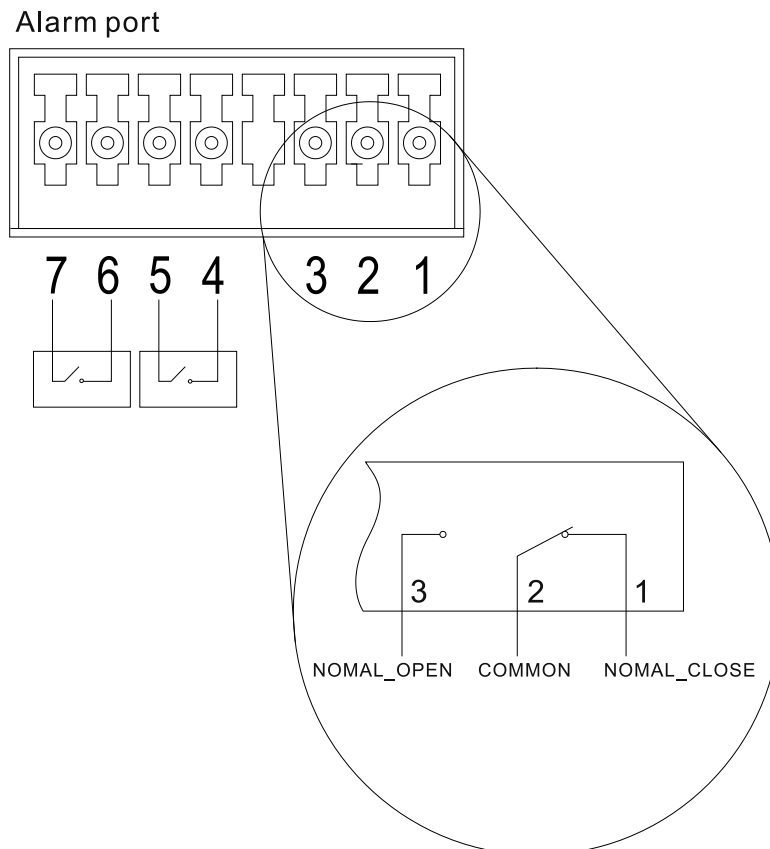

**Figure 2-4 Connecting a DC power source to the Switch**

1. Make sure that the ON/OFF toggle switch on the rear panel of the Switch is turned off.
2. Connect one end of the DC power cords supplied to a DC power source that will be activated when the AC power is not working. Make sure that connection polarity (positive and negative) is correct at both sides before using this feature to avoid any damaged.
3. Connect the other end of the DC power cords to the DC power source connector.
4. Connect the DC power source connector to the switch.
5. Turn the ON/OFF toggle switch on.

## Alarm Connector (DGS-3000-24TC/26TC Only)

The alarm connector can be used to use external devices when triggered events occur.



**Figure 2-5 Alarm Connector**

The following table describes the alarm connector port pin layout.

Contact	Description
1	Output. Normal Closed Pin. (42VAC or 60VDC)
2	Output. Common Pin. (42VAC or 60VDC)
3	Output. Normal Open Pin. (42VAC or 60VDC)
4	Input 2
5	Input 2
6	Input 1
7	Input 1

Connect the alarm input pins to alarm output terminals on other pieces of equipment.  
 Connect the alarm output pins to alarm input terminals on other pieces of equipment.

## Installing Power Cord Clip

To prevent accidental removal of the AC power cord, it is recommended to install the power cord clip together with the power cord.

1. With the rough side facing down, insert the Tie Wrap into the hole below the power socket.

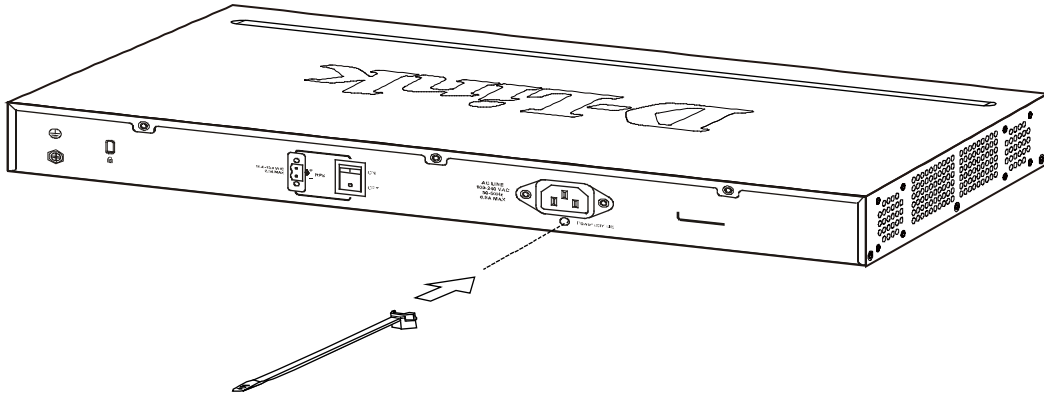

**Figure 2-6 Insert Tie Wrap to the Switch**

2. Plug the AC power cord into the power socket of the Switch.

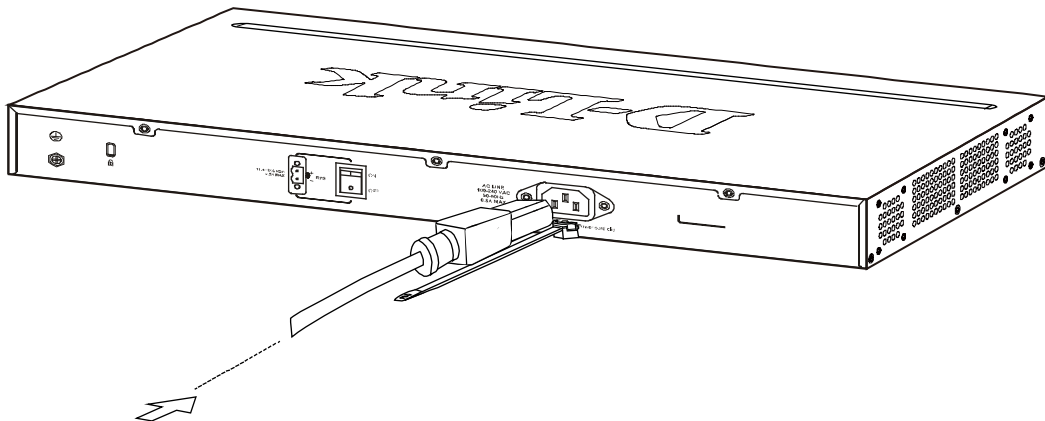

**Figure 2-7 Connect the power cord to the Switch**

- Slide the Retainer through the Tie Wrap until the end of the cord.

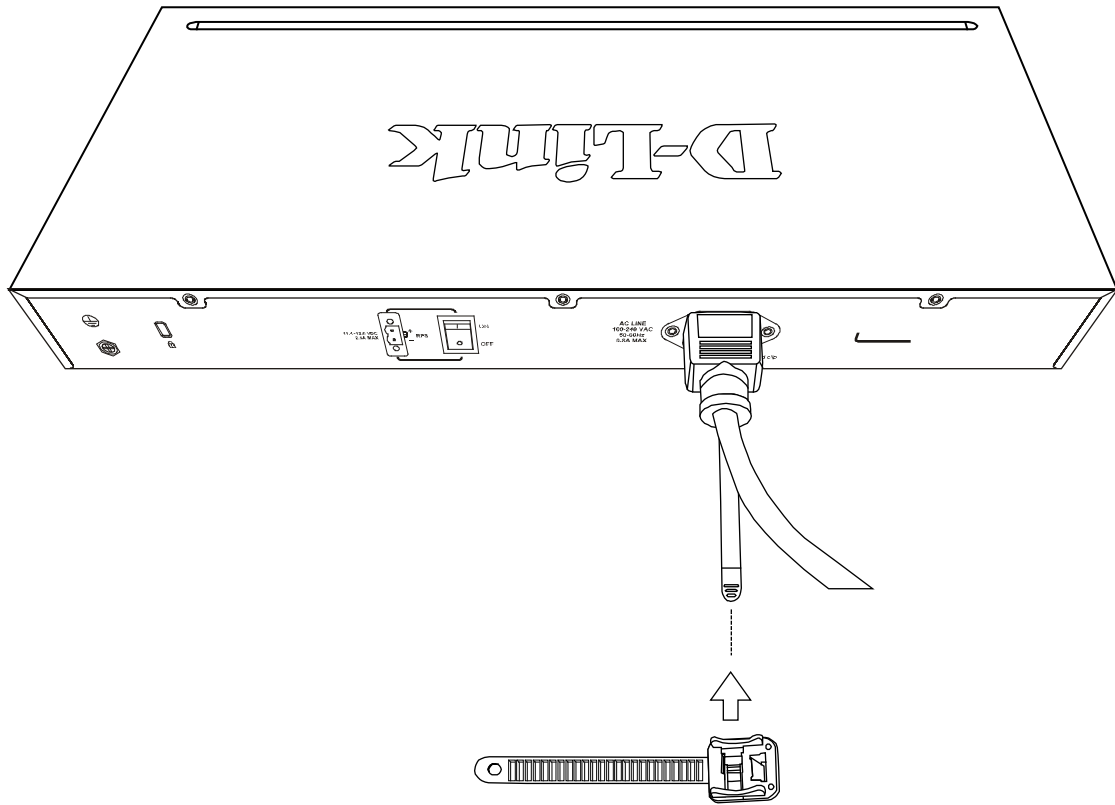

**Figure 2-8 Slide the Retainer through the Tie Wrap**

- Circle the tie of the Retainer around the power cord and into the locker of the Retainer.

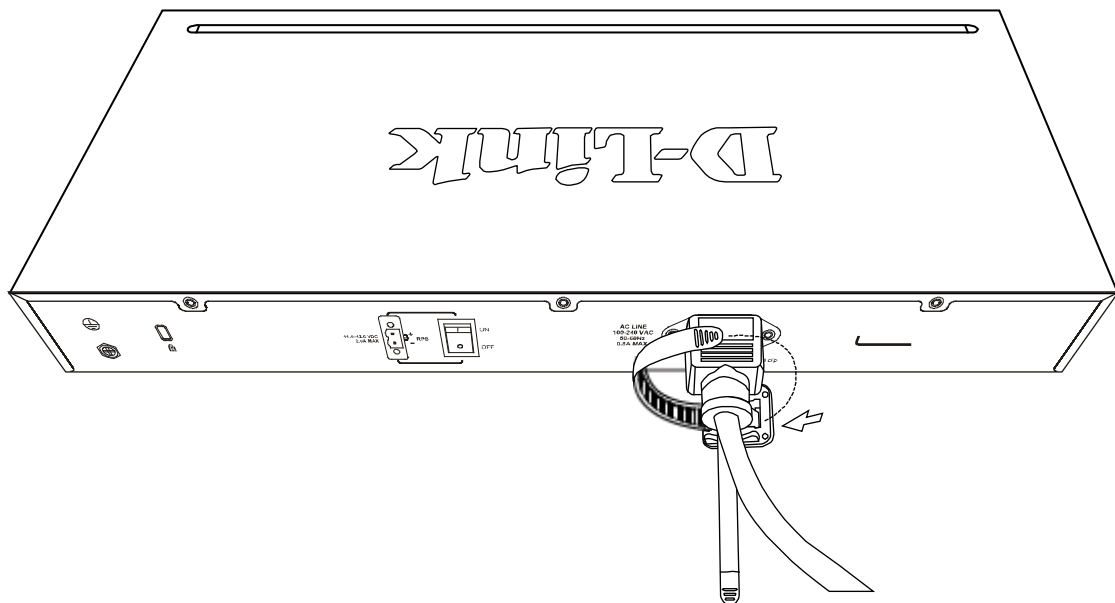

**Figure 2-9 Circle around the power cord**

5. Fasten the tie of the Retainer until the power cord is secured.

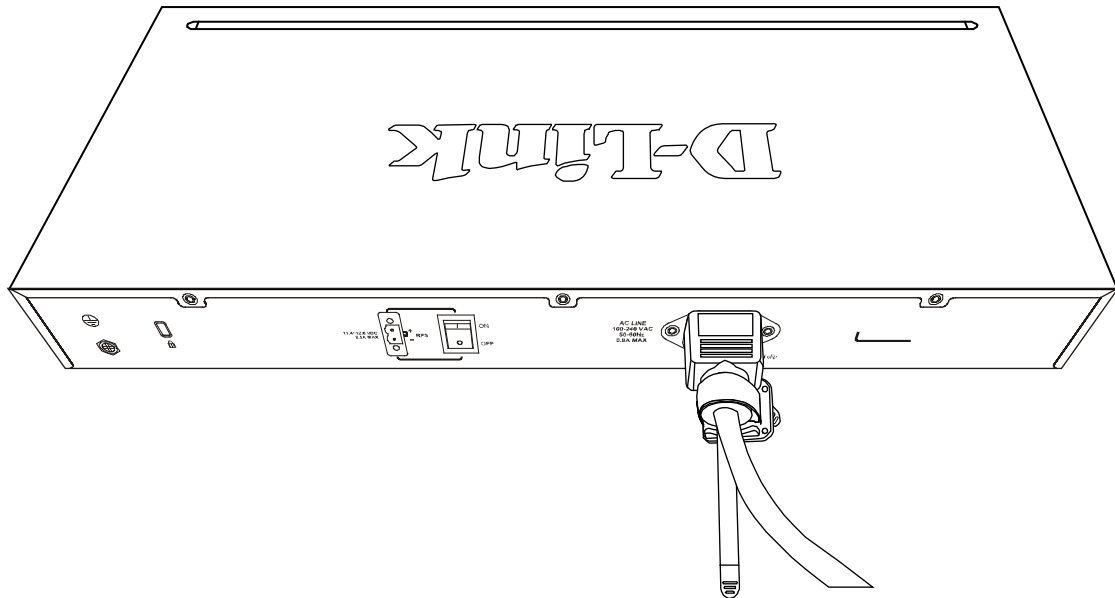
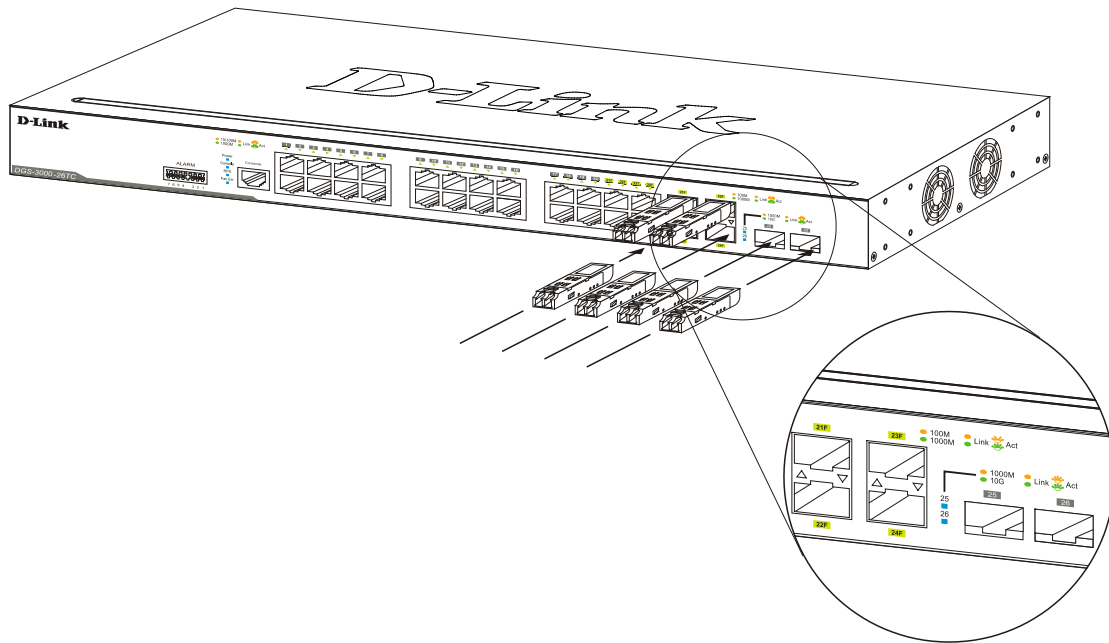

**Figure 2-10 Secure the power cord**

## Installing SFP and SFP+ Ports

The Switch is equipped with SFP (Small Form Factor Portable) and/or SFP+ ports, which are used with fiber-optical transceiver cabling. SFP ports support full-duplex transmissions, auto-negotiation, and can be uplinked with various other switches across a gigabit network. The SFP ports support data rates of up to 1Gbit/s and the SFP+ ports support data rates of up to 10Gbit/s.

See the figure below for installing the SFP ports in the Switch.



**Figure 2-11 Inserting fiber-optic transceivers into the Switch**

For a full list of supported transceivers, compatible with this switch series, refer to [Port Functions](#).



## Connecting the DPS-200 to the RPS Port

The DPS-200 redundant power supply can be connected to the RPS port of the Switch using the DC power supply cord, called the DPS-CB150-2PS. It is important to notice that the DPS-200 can supply power to one or two DGS-3000 Series Switches at the same time.

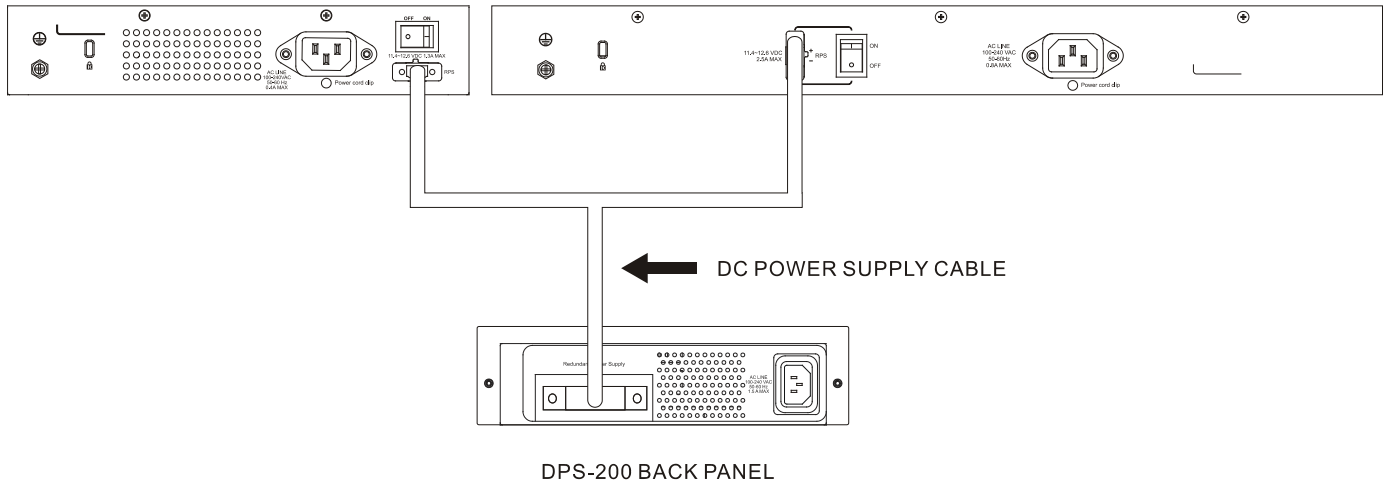

**Figure 2-12 Connecting two Switches to the DPS-200**

The following section explains how to connect the DPS-200 to the Switch.

1. Disconnect the Switch from the main AC power source.
2. Insert the 14-pin end of the DPS-CB150-2PS into the DPS-200 and the 2-pin end into the receptacle of the RPS port on the Switch.
3. Using a standard AC power cord, connect the DPS-200 to the main AC power source. A green LED on the front panel of the DPS-200 will illuminate to indicate a successful connection.
4. Make sure that the ON/OFF toggle switch on the rear panel of the Switch is turned on.
5. Re-connect the Switch to the AC power source and power on the DPS-200.

No configuration is needed in the Switch software for this installation.



**NOTE:** See the DPS-200 Quick Installation Guide for more information.

## Installing the RPS into a Rack-mount Chassis

The DPS-200 is the redundant power supply unit designed to conform to the voltage requirements of the RPS port of the Switch being supported. The DPS-200 can be installed into a DPS-800 and a DPS-900 rack-mount chassis unit.



**CAUTION:** DO NOT connect the RPS to the AC power before the DC power cable is connected. Connecting the AC power before the DC power is connected might damage the internal power supply.

### DPS-800 Rack-mount Chassis

The DPS-800 is a standard-size rack-mount (1 standard unit in height) designed to hold up to two DPS-200 redundant power supplies.

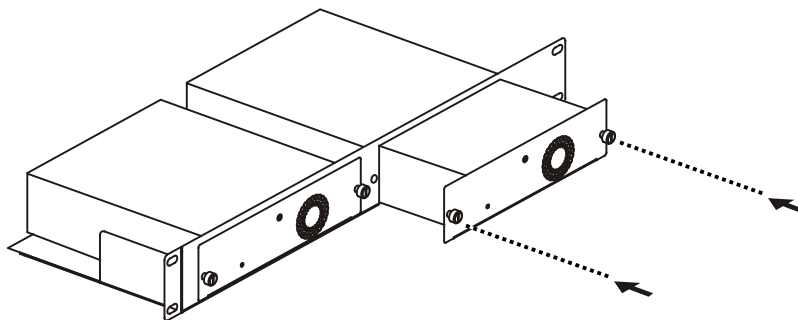

**Figure 2-13** Installing the DPS-200 in the DPS-800

The DPS-800 rack-mount chassis can be mounted into a standard 19" rack. Use the following diagram to guide you.

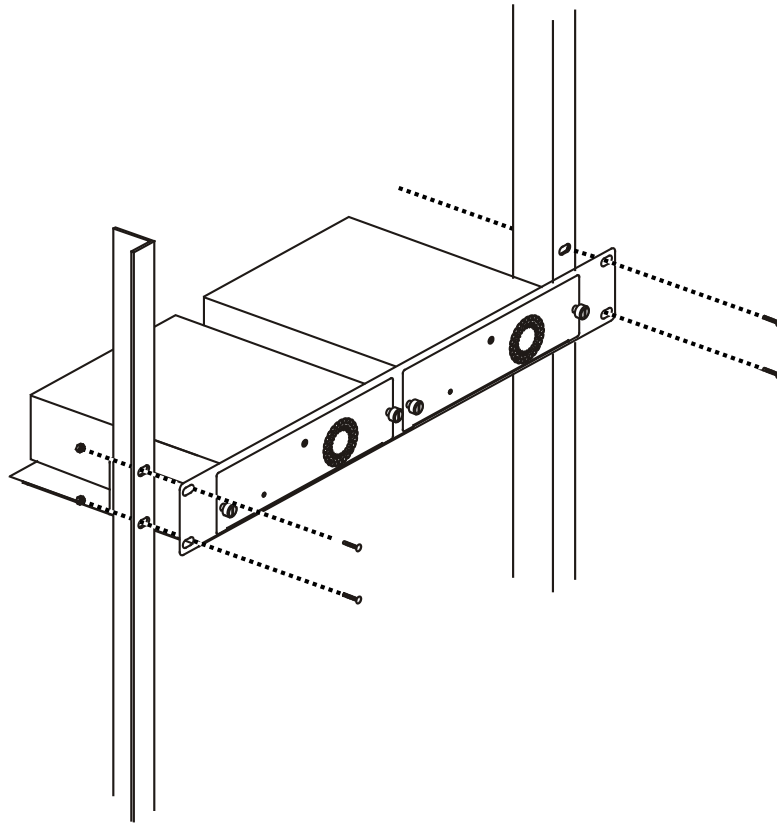

Figure 2-14 Installing the DPS-800 into a rack

## DPS-900 Rack-mount Chassis

The DPS-900 is a standard-size rack-mount (5 standard units in height) designed to hold up to eight DPS-200 redundant power supplies.

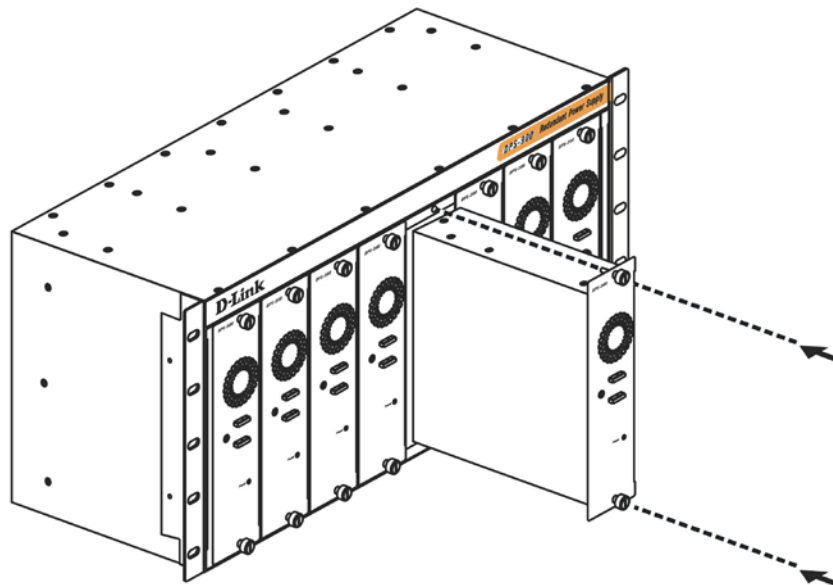

Figure 2-15 Inserting the DPS-200 into the DPS-900

The DPS-900 rack-mount chassis can be mounted into a standard 19" rack. Use the following diagram to guide you.

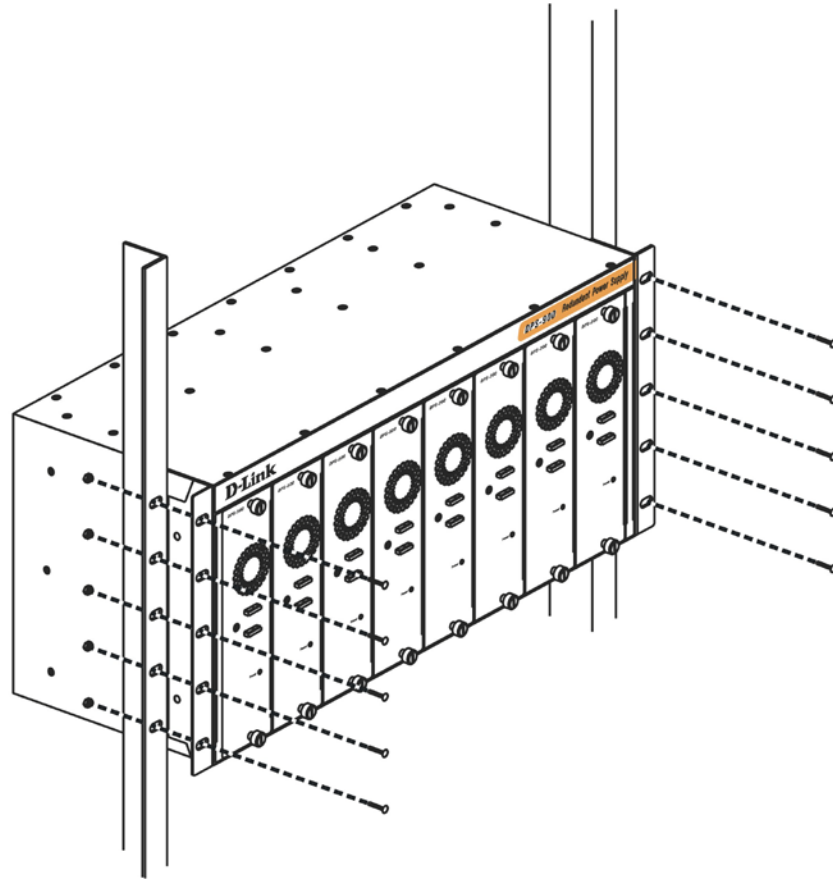

Figure 2-16 Installing the DPS-900 into a rack



**CAUTION:** Installing systems in a rack without the front and side stabilizers installed could cause the rack to tip over, potentially resulting in bodily injury under certain circumstances. Therefore, always install the stabilizers before installing components in the rack. After installing components in a rack, do not pull more than one component out of the rack on its slide assemblies at one time. The weight of more than one extended component could cause the rack to tip over and may result in injury.

# Chapter 3 Connecting the Switch

- Switch to End Node*
- Switch to Switch*
- Connecting To Network Backbone or Server*



**NOTE:** All high-performance N-Way Ethernet ports can support both MDI-II and MDI-X connections.

## Switch to End Node

End nodes include PCs outfitted with a 10, 100 or 1000 Mbps RJ-45 Ethernet Network Interface Card (NIC) and routers. An end node connects to the Switch via a twisted-pair UTP/STP cable. Connect the end node to any of the 1000BASE-T ports of the Switch. The Link/Act LEDs for each Ethernet port will light green or amber when the link is valid. A blinking LED indicates packet activity on that port.

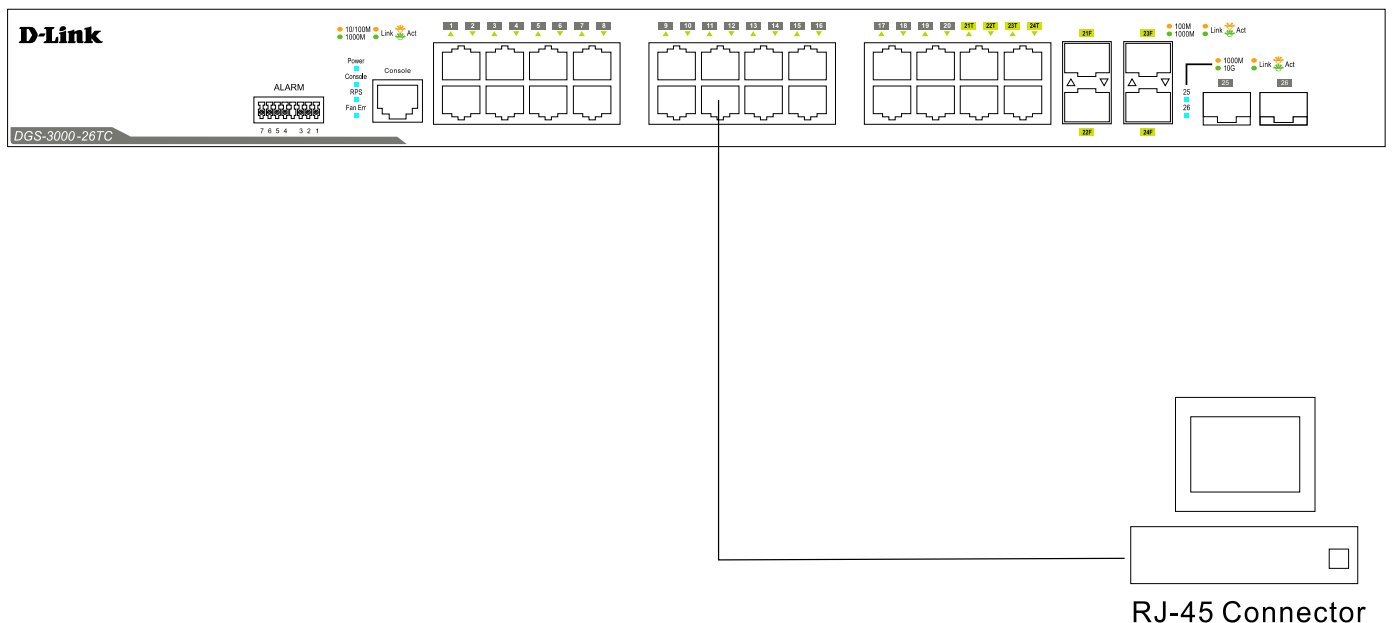
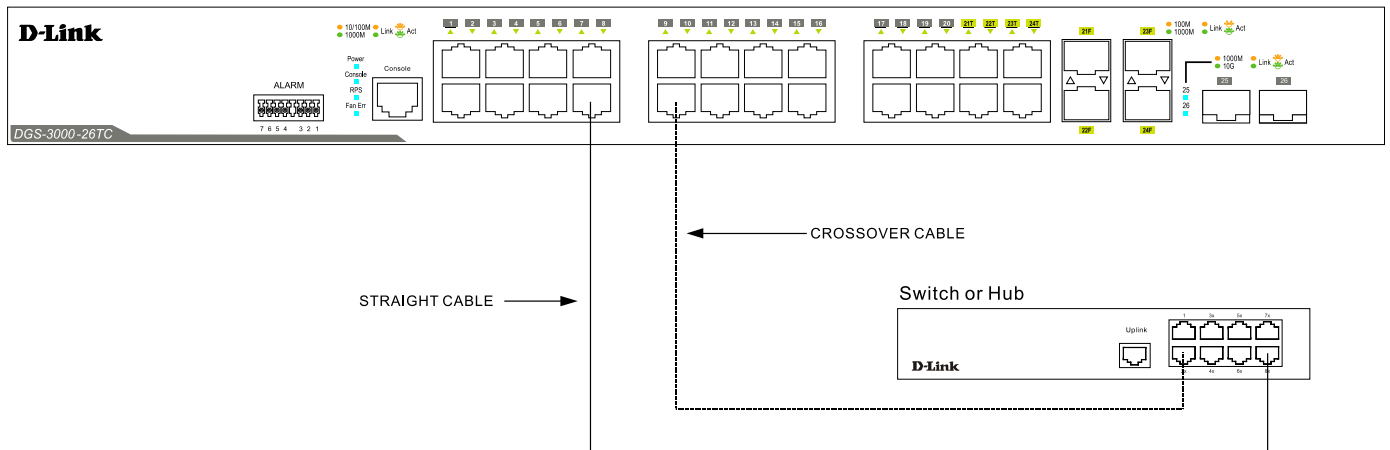

**Figure 3-1** Connecting the Switch to an end node

## Switch to Switch

There is a great deal of flexibility on how connections are made using the appropriate cabling.

- Connect a 10BASE-T switch port to the Switch via a twisted-pair Category 3, 4 or 5 UTP/STP cable.
- Connect a 100BASE-TX switch port to the Switch via a twisted-pair Category 5 UTP/STP cable.
- Connect 1000BASE-T switch port to the Switch via a twisted pair Category 5e UTP/STP cable.
- Connect switch supporting a fiber-optic uplink to the Switch's SFP/SFP+ ports via fiber-optic cabling. See cabling guidelines in **Appendix B** for more information.



**Figure 3-2 Connecting a Switch to another switch**

## Connecting to Network Backbone or Server

The combo SFP ports and the 1000BASE-T ports are ideal for uplinking to a network backbone, server or server farm. The copper ports operate at a speed of 10, 100 or 1000Mbps in full or half duplex mode. The fiber-optic ports can operate at both 100Mbps and 1000Mbps in full duplex mode.

Connections to the Gigabit Ethernet ports are made using a fiber-optic cable or Category 5e copper cable, depending on the type of port. A valid connection is indicated when the Link LED is lit.

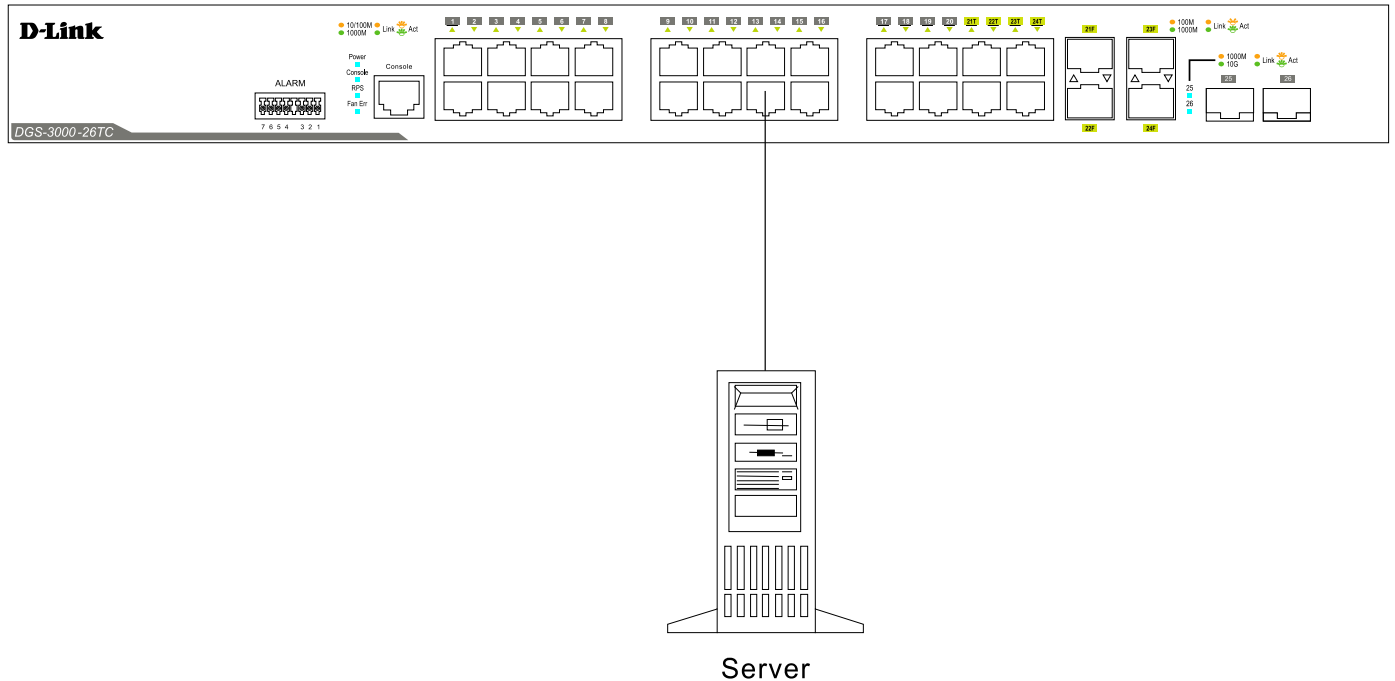

Figure 3-3 Connecting the Switch to a server

# Chapter 4 Introduction to Switch Management

## *Management Options*

### *Connecting the Console Port*

### *First Time Connecting to the Switch*

### *Password Protection*

### *IP Address Assignment*

### *SNMP Settings*

## Management Options

This system may be managed out-of-band through the console port on the front panel or in-band using Telnet. The user may also choose the Web-based management, accessible through a Web browser.

### **Web-based Management Interface**

After successfully installing the Switch, the user can configure the Switch, monitor the LED panel, and display statistics graphically using a Web browser, such as Microsoft® Internet Explorer (version 5.5 and later), Netscape (version 8 and later), Mozilla Firefox (version 2.0 and later), Safari (version 4.0 and later), and Google Chrome (version 6.0 and later).

### **SNMP-based Management**

The Switch can be managed with an SNMP-compatible console program. The Switch supports SNMP version 1.0, version 2.0 and version 3.0. The SNMP agent decodes the incoming SNMP messages and responds to requests with MIB objects stored in the database. The SNMP agent updates the MIB objects to generate statistics and counters.

### **Command Line Interface through the Serial Port or remote Telnet**

The user can also connect a computer or terminal to the serial console port to access the Switch. The command line interface provides complete access to all Switch management features.

## Connecting the Console Port

The front panel of the Switch provides a port that enables a connection to a computer monitoring and configuring the Switch. The console port is an RJ-45 port and requires a special cable that is included with the Switch, to establish the physical connection.

To use the console port, the following equipment is needed:

- A terminal or a computer with both an RS-232 serial port and the ability to emulate a terminal.
- A console cable with a male DB-9 connector on one end and an RJ-45 connection on the other. This cable should be included with the Switch. It establishes the physical connection to the console port.

### **To connect a terminal to the console port:**

Connect the male DB-9 connector on the console cable (shipped with the Switch) to the RS-232 serial port on the computer running terminal emulation software then insert the RJ-45 connector into the RJ-45 console port on the front of the Switch. Set the terminal emulation software as follows:

- Select the appropriate serial port (COM port 1 or COM port 2).
- Set the data rate to 115200 baud.
- Set the data format to 8 data bits, 1 stop bit, and no parity.
- Set flow control to None.
- Under Properties, select VT100 for Emulation mode.



- Select Terminal keys for Function, Arrow and Ctrl keys. Make sure to use Terminal keys (not Windows keys) are selected.



**NOTE:** When using HyperTerminal with the Microsoft® Windows® 2000 operating system, ensure that Windows 2000 Service Pack 2 or later is installed. Windows 2000 Service Pack 2 allows use of arrow keys in HyperTerminal's VT100 emulation. See [www.microsoft.com](http://www.microsoft.com) for information on Windows 2000 service packs.

- After you have correctly set up the terminal, plug the power cord into the power receptacle on the back of the Switch. The boot sequence appears in the terminal.
- After the boot sequence completes, the console login screen displays.
- If the user has not logged into the command line interface (CLI) program, press the Enter key at the User name and password prompts. There is no default user name and password for the Switch. The administrator must first create user names and passwords. If user accounts have been previously set up, log in and continue to configure the Switch.
- Enter the commands to complete desired tasks. Many commands require administrator-level access privileges. Read the next section for more information on setting up user accounts. See the **DGS-3000 Series CLI Reference Guide** on the documentation CD for a list of all commands and additional information on using the CLI.
- To end a management session, use the logout command or close the emulator program.

If problems occur in making this connection on a PC, make sure the emulation is set to VT-100. The emulation settings can be configured by clicking on the File menu in the HyperTerminal window by clicking on Properties in the drop-down menu, and then clicking the Settings tab. This is where you will find the Emulation options. If you still do not see anything, try rebooting the Switch by disconnecting its power supply.

Once connected to the console, the screen on the next page will appear on the console. This is where the user will enter commands to perform all the available management functions. The Switch will prompt the user to enter a user name and a password. Upon the initial connection, there is no user name or password and therefore just press Enter twice to access the command line interface.

```

Boot Procedure                                     V1.00.002
-----
Power On Self Test ..... 100 %

MAC Address   : 00-01-02-03-04-00
H/W Version   : A1

Please Wait, Loading V1.10.008 Runtime Image ..... 100 %
UART init ..... 100 %
Starting runtime image
Device Discovery ..... |
    
```

**Figure 4-1 Boot up display in console screen**

## First Time Connecting to the Switch

The Switch supports user-based security that can allow prevention of unauthorized users from accessing the Switch or changing its settings. This section tells how to log onto the Switch via out-of-band console connection or out-of-band Management port connection.

Upon initial connection to the Switch, the login screen appears (see example below).

```
DGS-3000-26TC Gigabit Ethernet Switch
Command Line Interface

Firmware: Build 1.10.008
Copyright(C) 2014 D-Link Corporation. All rights reserved.
UserName:
```

**Figure 4-2 Initial screen, first time connecting to the Switch**

Press **Enter** in both the Username and Password fields. Then access will be given to enter commands after the command prompt **DGS-3000-26TC:admin#**

There is no initial username or password. Leave the Username and Password fields blank.



**NOTE:** The first user automatically gets Administrator level privileges. At least one Admin-level user account must be created for the Switch.

## Password Protection

The Switch does not have a default user name and password. One of the first tasks when settings up the Switch is to create user accounts. Logging in using a predefined administrator-level user name will give the user privileged access to the Switch's management software.

After the initial login, define new passwords for both default user names to prevent unauthorized access to the Switch, and record the passwords for future reference.

To create an administrator-level account for the Switch, do the following:

1. At the CLI login prompt, enter create account admin followed by the *<user name>* and press the **Enter** key.
2. The Switch will then prompt the user to provide a password. Type the *<password>* used for the administrator account being created and press the **Enter** key.
3. Once entered, the Switch will again ask the user to enter the same password again to verify it. Type the same password and press the **Enter** key.
4. A "Success" response by the Switch will verify the creation of the new administrator.



**NOTE:** Passwords are case sensitive. User names and passwords can be up to 15 characters in length.

## IP Address Assignment

An IP address must be assigned to each switch, which is used for communication with an SNMP network manager or other TCP/IP application (for example BOOTP, TFTP). The Switch's default IP address is 10.90.90.90. The user may change the default Switch IP address to meet the specification of your networking address scheme.

The Switch is also assigned a unique MAC address by the factory. This MAC address cannot be changed, and can be found by entering the command "**show switch**" into the command line interface.

The Switch's MAC address also appears in the **Device Information** and **System Information** windows of the Web-based management interface. The IP address for the Switch must be set before using the Web-based manager. The Switch IP address can be automatically set using BOOTP or DHCP protocols, in which case the actual address assigned to the Switch must be known.

## SNMP Settings

Simple Network Management Protocol (SNMP) is an OSI Layer 7 (Application Layer) designed specifically for managing and monitoring network devices. SNMP enables network management stations to read and modify the settings of gateways, routers, switches and other network devices. Use SNMP to configure system features for proper operation, monitor performance and detect potential problems in the Switch, switch group or network.

Managed devices that support SNMP include software (referred to as an agent), which runs locally on the device. A defined set of variables (managed objects) is maintained by the SNMP agent and used to manage the device. These objects are defined in a Management Information Base (MIB), which provides a standard presentation of the information controlled by the on-board SNMP agent. SNMP defines both the format of the MIB specifications and the protocol used to access this information over the network.

The Switch supports SNMP versions 1, 2c, and 3. The administrator may specify which version of SNMP to use to monitor and control the Switch. The three versions of SNMP vary in the level of security provided between the management station and the network device.

In SNMP v1 and v2, user authentication is accomplished using 'community strings', which function like passwords. The remote user SNMP application and the Switch SNMP must use the same community string. SNMP packets from any station that has not been authenticated are ignored (dropped).

The default community strings for the Switch used for SNMP v1 and v2 management access are:

- public - Allows authorized management stations to retrieve MIB objects.
- private - Allows authorized management stations to retrieve and modify MIB objects.

SNMP v3 uses a more sophisticated authentication process that is separated into two parts. The first part is to maintain a list of users and their attributes that are allowed to act as SNMP managers. The second part describes what each user on that list can do as an SNMP manager.

The Switch allows groups of users to be listed and configured with a shared set of privileges. The SNMP version may also be set for a listed group of SNMP managers. Thus, a group of SNMP managers can be created to view read-only information or receive traps using SNMP v1 while assigning a higher level of security to another group, granting read/write privileges using SNMP v3.

Using SNMP v3 individual users or groups of SNMP managers can be allowed to perform or be restricted from performing specific SNMP management functions. The functions allowed or restricted are defined using the Object Identifier (OID) associated with a specific MIB. An additional layer of security is available for SNMP v3 in that SNMP messages may be encrypted. To read more about how to configure SNMP v3 settings for the Switch read the section entitled Management.

## Traps

Traps are messages that alert network personnel of events that occur on the Switch. The events can be as serious as a reboot (someone accidentally turned OFF the Switch), or less serious like a port status change. The Switch generates traps and sends them to the trap recipient (or network manager). Typical traps include trap messages for Authentication Failure, Topology Change and Broadcast/Multicast Storm.

## MIBs

The Switch in the Management Information Base (MIB) stores management and counter information. The Switch uses the standard MIB-II Management Information Base module. Consequently, values for MIB objects can be retrieved from any SNMP-based network management software. In addition to the standard MIB-II, the Switch also supports its own proprietary enterprise MIB as an extended Management Information Base. The proprietary MIB may also be retrieved by specifying the MIB Object Identifier. MIB values can be either read-only or read-write.

# Chapter 5 Web-based Switch Configuration

## Introduction

### Logging onto the Web Manager

### Web-based User Interface

### Web Pages

## Introduction

Most software functions of the Switch can be managed, configured, and monitored via the embedded Web-based (HTML) interface. Manage the Switch from remote stations anywhere on the network through a standard browser, such as Internet Explorer (version 5.5 and later), Netscape (version 8.0 and later), Mozilla Firefox (version 2.0 and later), Safari (version 4.0 and later), or Google Chrome (version 6.0 and later). The browser acts as a universal access tool and can communicate directly with the Switch using the HTTP protocol.

## Logging onto the Web Manager

To begin managing the Switch, simply run the browser installed on your computer and point it to the IP address you have defined for the device. The URL in the address bar should read something like: `http://123.123.123.123`, where the numbers 123 represent the IP address of the Switch.



**NOTE:** The factory default IP address is 10.90.90.90/8.

This opens the management module's user authentication window, as seen below.

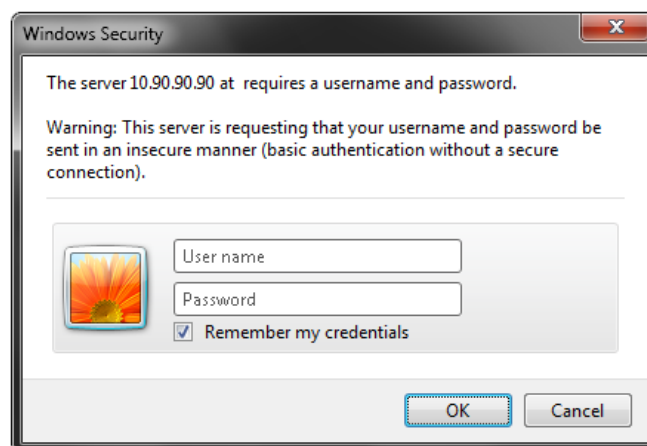

**Figure 5-1 Enter Network Password window**

As there is no default User name or Password, click **OK** to proceed. This will open the Web-based user interface. The Switch management features available in the Web-based manager are explained below.

## Web-based User Interface

The user interface provides access to various Switch configuration and management windows, allows the user to view performance statistics, and permits graphical monitoring of the system status.

### Areas of the User Interface

The figure below shows the user interface. Three distinct areas divide the user interface, as described in the table.

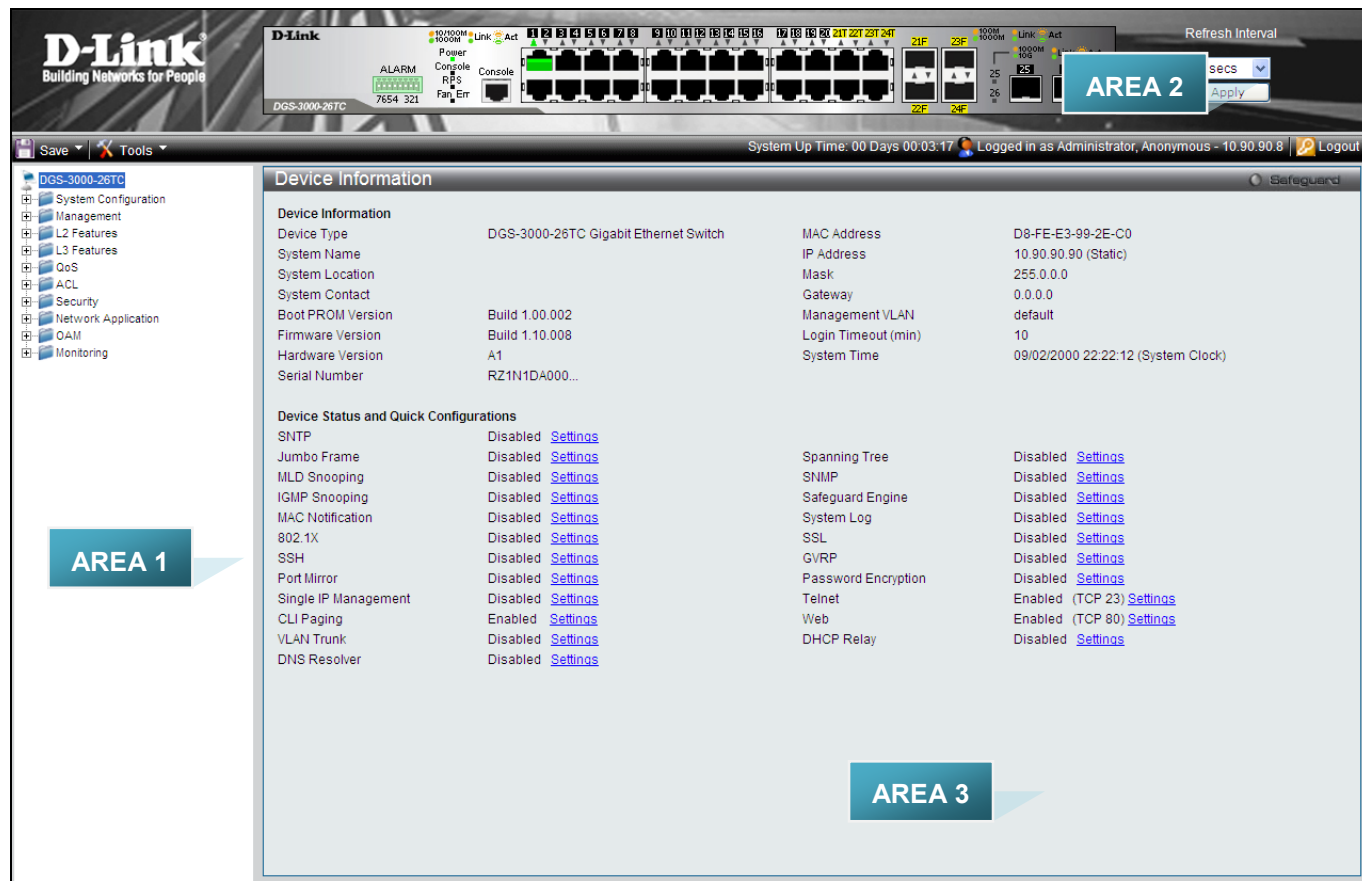

Figure 5-2 Main Web Manager window

Area Number	Function
Area 1	Select the menu or window to display. Open folders and click the hyperlinked menu buttons and subfolders contained within them to display menus. Click the D-Link logo to go to the D-Link website.
Area 2	Presents a graphical near real-time image of the front panel of the Switch. This area displays the Switch's ports, console and management port, showing port activity. Some management functions, including save, reboot, download and upload are accessible here.
Area 3	Presents switch information based on user selection and the entry of configuration data.

## Web Pages

When connecting to the management mode of the Switch with a Web browser, a login screen is displayed. There is no default user name or password necessary to access the Switch's management mode.



**NOTE:** Be sure to configure the user name and password in the User Accounts window before connecting the Switch to the greater network.

# Appendix Section

## Appendix A – Technical Specifications

### General

Feature	Detailed Description										
<b>Standards</b>	IEEE 802.1D/2004/Spanning Tree (802.1s, 802.1w) IEEE 802.1Q-2005 VLAN IEEE 802.1p Priority Queues IEEE 802.1X Network Access Control IEEE 802.3 Nway Auto-negotiation IEEE 802.3ad Link Aggregation Control IEEE 802.3az Energy-Efficient Ethernet IEEE 802.3 10BASE-T Ethernet IEEE 802.3u 100BASE-TX Fast Ethernet IEEE 802.3ab 1000BASE-T Gigabit Ethernet IEEE 802.3z 1000BASE-T (SFP “Mini GBIC”) IEEE 802.3ae 10GBASE-X/10GBASE-R/10GBASE-W IEEE 802.3aq 10GBASE-LRM										
<b>Protocols</b>	CSMA/CD										
<b>Data Transfer Rates:</b> <b>Ethernet</b> <b>Fast Ethernet</b> <b>Gigabit Ethernet</b> <b>10 Gigabit Ethernet</b>	<table> <tr> <td>Half-duplex</td> <td>Full-duplex</td> </tr> <tr> <td>10 Mbps</td> <td>20Mbps</td> </tr> <tr> <td>100Mbps</td> <td>200Mbps</td> </tr> <tr> <td>-----</td> <td>2Gbps</td> </tr> <tr> <td>-----</td> <td>20Gbps</td> </tr> </table>	Half-duplex	Full-duplex	10 Mbps	20Mbps	100Mbps	200Mbps	-----	2Gbps	-----	20Gbps
Half-duplex	Full-duplex										
10 Mbps	20Mbps										
100Mbps	200Mbps										
-----	2Gbps										
-----	20Gbps										
<b>Network Cables</b>	Cat.5 Enhanced for 1000BASE-T UTP Cat.5, Cat. 5 Enhanced for 100BASE-TX UTP Cat.3, 4, 5 for 10BASE-T EIA/TIA-568 100-ohm screened twisted-pair (STP)(100m)										
<b>Number of Ports</b>	<b>DGS-3000-10TC:</b> Eight Copper ports (10/100/1000Mbps), Two Combo Copper/SFP ports (10/100/1000Mbps and 100/1000Mbps). <b>DGS-3000-24TC:</b> Twenty Copper ports (10/100/1000Mbps), Four Combo Copper/SFP ports (10/100/1000Mbps and 100/1000Mbps). <b>DGS-3000-26TC:</b> Twenty Copper ports (10/100/1000Mbps), Four Combo Copper/SFP ports (10/100/1000Mbps and 100/1000Mbps), Two SFP+ ports (1000Mbps/10Gbps).										

### Physical and Environmental

Feature	Detailed Description
<b>Internal Power Supply</b>	AC Input: 100 – 240 VAC, 50-60 Hz
<b>Optional Redundant Power Supply</b>	Provides one connector in rear panel to install optional external RPS to enhance the reliability. When internal power is failed, the optional external RPS will take over all the power immediately and automatically.
<b>Security Lock</b>	Provides a Kensington-compatible security lock, at the rear of the switch, to be able to connect to a secure immovable device. Insert the lock into the notch and turn the key to secure the lock. The lock-and-cable apparatus should be purchased separately.



<b>Power Consumption</b>	<b>DGS-3000-10TC:</b> 16.5 Watts (Max.) <b>DGS-3000-24TC:</b> 21.5 Watts (Max.) <b>DGS-3000-26TC:</b> 29.6 Watts (Max.)
<b>Operating Temperature</b>	0°C to 50°C
<b>Storage Temperature</b>	-40°C to 70°C
<b>Humidity</b>	<b>Operation:</b> 10% to 90% RH non-condensing <b>Storage:</b> 5% to 90% RH non-condensing
<b>Dimensions</b>	<b>DGS-3000-10TC:</b> 228.5mm (W) x 195mm (D) x 44mm (H) <b>DGS-3000-24TC:</b> 440mm (W) x 209.9mm (D) x 44mm (H) <b>DGS-3000-26TC:</b> 440mm (W) x 209.9mm (D) x 44mm (H)
<b>Weight</b>	<b>DGS-3000-10TC:</b> 1.1 kg <b>DGS-3000-24TC:</b> 2.04 kg <b>DGS-3000-26TC:</b> 2.05 kg
<b>EMI/EMC; RF Certificates and Test Reports</b>	CE Report (2004/108/EC), EN 55022:2006, EN 55024:1998+A1: 2001+A2:2003, EN 61000-3-2:2006, EN 61000-3-3 :1995+A1: 2001+A2: 2005, FCC report (FCC CFR 47 Part 15 B), IC report (ICES-003), C-Tick Report (AS/NZS CISPR 22), VCCI Report (CISPR 22), BSMI(CNS 13438: 95-06-01 甲類 (完整版))
<b>Safety Certificates and Test Reports</b>	UL/CSA 60950-1, IEC60950-1: 2001, EN60950-1: 2001, BSMI(CNS 14336-1 (民國 99 年版))

## Performance

Feature	Detailed Description
<b>Transmission Method</b>	Store-and-forward
<b>Packet Buffer</b>	1.5 MByte (Max)
<b>Maximum Forwarding Rate</b>	<b>DGS-3000-10TC:</b> 14.88 million packets per second. <b>DGS-3000-24TC:</b> 35.71 million packets per second. <b>DGS-3000-26TC:</b> 65.48 million packets per second.
<b>Switching Capability</b>	<b>DGS-3000-10TC:</b> 20Gbps <b>DGS-3000-24TC:</b> 48Gbps <b>DGS-3000-26TC:</b> 88Gbps
<b>Priority Queues</b>	8 Priority Queues per port
<b>MAC Address Table</b>	Supports 16K MAC addresses
<b>Wire Speed</b>	Full-wire speed (full-duplex) operation on all ports including Gigabit ports.
<b>Virtual Stacking / Clustering</b>	<ol style="list-style-type: none"> <li>Support D-Link Single IP Management v1.6</li> <li>Manage up to 32 devices in a virtual stack with a single IP address.</li> </ol>

## LED Indicators

Location	LED Indicative	Color	Status	Description
<b>Per Device</b>	<b>Power</b>	Green	Solid Light	Power on.
			Light off	Power off.
	<b>Console</b>	Green	Solid Light	Console on.
			Light off	Console off.

	<b>RPS</b>	Green	Solid Light	RPS is connected and the RPS switch is turned on.
			Light off	RPS is not connected or the RPS switch is turned off.
	<b>Fan Err</b>	Red	Blinking	When any of the fans has failed.
			Light off	When all fans work normally.
<b>LED Per 10/100/1000 Mbps Port</b>	<b>Link/Act/Speed Mode</b>	Green	Solid Light	When there is a secure connection (or link) to 1000Mbps Ethernet device at any of the ports.
			Blinking	When there is reception or transmission of data occurring at 1000Mbps.
		Orange	Solid Light	When there is a secure connection (or link) to 10/100Mbps Ethernet device at any of the ports.
			Blinking	When there is reception or transmission of data occurring at 10/100Mbps.
		Off	Light off	No link.
		<b>LED Per SFP Port</b>	<b>Link/Act</b>	Green
Blinking	When there is reception or transmission of data occurring at 1000Mbps.			
Orange	Solid Light			When there is a secure connection (or link) to 100Mbps Ethernet device at any of the ports.
	Blinking			When there is reception or transmission of data occurring at 100Mbps.
Off	Light off			No link.
<b>LED Per SFP+ Port</b>	<b>Link/Act</b>			Green
		Blinking	When there is reception or transmission of data occurring at 10Gbps.	
		Orange	Solid Light	When there is a secure connection (or link) to 1Gbps Ethernet device at any of the ports.
			Blinking	When there is reception or transmission of data occurring at 1Gbps.
		Off	Light off	No link.

## Port Functions

Feature	Detailed Description
<b>Console Port</b>	RJ-45 interface for Out-Of-Band (OOB) CLI configuration.
<b>Copper Ports</b>	<p><b>Compliant with the following standards:</b></p> <ul style="list-style-type: none"> <li>• IEEE 802.3 compliance</li> <li>• IEEE 802.3u compliance</li> <li>• IEEE 802.3ab compliance</li> <li>• IEEE 802.3az compliance (100/1000Mbps)</li> <li>• Support Half/Full-Duplex operations</li> <li>• Auto-negotiation</li> <li>• Auto MDI/MDIX</li> <li>• IEEE 802.3x Flow Control support for Full-Duplex mode, Back Pressure when Half-Duplex mode, and Head-of-line blocking prevention</li> </ul>
<b>SFP Ports</b>	<p><b>Compliant with the following standards:</b></p> <ul style="list-style-type: none"> <li>• IEEE 802.3z compliance</li> <li>• IEEE 802.3x Flow Control support for Full-Duplex mode</li> <li>• Support Auto-negotiation for Full-Duplex/ flow control operations</li> </ul> <p><b>SFP Transceivers supported:</b></p> <ul style="list-style-type: none"> <li>• DEM-310GT (1000BASE-LX, Single-mode, 10km)</li> <li>• DEM-311GT (1000BASE-SX, Multi-mode, 550m)</li> <li>• DEM-312GT2 (1000BASE-SX, Multi-mode, 2km)</li> <li>• DEM-314GT (1000BASE-LHX, Single-mode, 50km)</li> <li>• DEM-315GT (1000BASE-ZX, Single-mode, 80km)</li> <li>• DEM-302S-LX (1000BASE-LX, Single-mode, 2km)</li> <li>• DEM-210 (100BASE-FX, Single-mode, 15km)</li> <li>• DEM-211 (100BASE-FX, Multi-mode, 2km)</li> <li>• DGS-712 (1000BASE-T, 1G Copper, 100m)</li> </ul> <p><b>WDM transceivers supported:</b></p> <ul style="list-style-type: none"> <li>• DEM-330T (1000BASE-BX, TX-1550/RX-1310nm, Single-mode, 10km)</li> <li>• DEM-330R (1000BASE-BX, TX-1310/RX-1550nm, Single-mode, 10km)</li> <li>• DEM-331T (1000BASE-BX, TX-1550/RX-1310nm, Single-mode, 40km)</li> <li>• DEM-331R (1000BASE-BX, TX-1310/RX-1550nm, Single-mode, 40km)</li> <li>• DEM-220T (100BASE-BX-D, TX-1550/RX-1310 nm, Single-mode, 20km)</li> <li>• DEM-220R (100BASE-BX-U, TX-1310/RX-1550 nm, Single-mode, 20km)</li> <li>• DEM-302S-BXD (1000BASE-LX, TX-1550/RX-1310 nm, Single-Mode, 2km)</li> <li>• DEM-302S-BXU (1000BASE-LX, TX-1310/RX-1550 nm, Single-Mode, 2km)</li> </ul>
<b>SFP+ Ports (DGS-3000-26TC Only)</b>	<p><b>Compliant with the following standards:</b></p> <ul style="list-style-type: none"> <li>• IEEE 802.3ae compliance</li> <li>• IEEE 802.3aq compliance</li> </ul> <p><b>SFP Transceivers supported:</b></p> <ul style="list-style-type: none"> <li>• DEM-310GT (1000BASE-LX, Single-mode, 10km)</li> <li>• DEM-311GT (1000BASE-SX, Multi-mode, 550m)</li> <li>• DEM-312GT2 (1000BASE-SX, Multi-mode, 2km)</li> <li>• DEM-314GT (1000BASE-LHX, Single-mode, 50km)</li> </ul>

	<ul style="list-style-type: none"> <li>• DEM-315GT (1000BASE-ZX, Single-mode, 80km)</li> <li>• DEM-302S-LX (1000BASE-LX, Single-mode, 2km)</li> </ul> <p><b>WDM transceivers supported:</b></p> <ul style="list-style-type: none"> <li>• DEM-330T (1000BASE-BX, TX-1550/RX-1310nm, Single-mode, 10km)</li> <li>• DEM-330R (1000BASE-BX, TX-1310/RX-1550nm, Single-mode, 10km)</li> <li>• DEM-331T (1000BASE-BX, TX-1550/RX-1310nm, Single-mode, 40km)</li> <li>• DEM-331R (1000BASE-BX, TX-1310/RX-1550nm, Single-mode, 40km)</li> <li>• DEM-302S-BXD (1000BASE-LX, TX-1550/RX-1310 nm, Single-Mode, 2km)</li> <li>• DEM-302S-BXU (1000BASE-LX, TX-1310/RX-1550 nm, Single-Mode, 2km)</li> </ul> <p><b>SFP+ Transceivers supported:</b></p> <ul style="list-style-type: none"> <li>• DEM-431XT (10GBASE-SR, (w/o DDM), 80m: OM1 &amp; OM2 MMF, 300m: OM3 MMF)</li> <li>• DEM-431XT-DD (10GBASE-SR, (with DDM), 80m: OM1 &amp; OM2 MMF, 300m: OM3 MMF)</li> <li>• DEM-432XT (10GBASE-LR, (w/o DDM), 10km)</li> <li>• DEM-432XT-DD (10GBASE-LR, (with DDM), 10km)</li> <li>• DEM-433XT (10GBASE-ER, (w/o DDM), 40km)</li> <li>• DEM-433XT-DD (10GBASE-ER, (with DDM), 40km)</li> <li>• DEM-435XT (10GBASE-LRM, (w/o DDM), 220m: OM1 &amp; OM2 MMF, 300m: OM3 MMF)</li> <li>• DEM-435XT-DD (10GBASE-LRM, (with DDM), 220m: OM1 &amp; OM2 MMF, 300m: OM3 MMF)</li> <li>• DEM-436XT-BXU (10GBASE-LR, BiDi (w/o DDM), 20km, TX: 1270nm, RX: 1330nm)</li> <li>• DEM-436XT-BXD (10GBASE-LR, BiDi (w/o DDM), 20km, TX: 1330nm, RX: 1270nm)</li> </ul> <p><b>SFP+ Direct Attached Cables (DAC) supported:</b></p> <ul style="list-style-type: none"> <li>• Direct Attached Cables are cables with built-in SFP+ transceivers at both ends.</li> <li>• DEM-CB100S (10GbE SFP+ 1m Direct Attach Cable)</li> <li>• DEM-CB300S (10GbE SFP+ 3m Direct Attach Cable)</li> <li>• DEM-CB500S (10GbE SFP+ 5m Direct Attach Cable)</li> <li>• DEM-CB700S (10GbE SFP+ 7m Direct Attach Cable)</li> </ul>
<b>RPS Port</b>	<ul style="list-style-type: none"> <li>• Supports the connection to an external redundant power supply. In the event that the AC internal power supply fails, the external RPS will take over the power supply.</li> </ul> <p><b>Redundant Power Supplies (RPSs) and accessories supported:</b></p> <ul style="list-style-type: none"> <li>• DPS-200 (60 Watt redundant power supply unit (includes RPSU cable and AC power cord))</li> <li>• DEM-CB150-2PS (1 DC input connector for DPS-200 and 2 DC output connectors for the Switch)</li> </ul>
<b>Alarm Port (DGS-3000-24TC and DGS-3000-26TC Only)</b>	<ul style="list-style-type: none"> <li>• Supports an alarm connector, on the front panel, that provides two external event detection input circuits and one alarm action output circuit.</li> <li>• Alarm action output circuit supports 42VAC, 50Hz, 1A maximum or 60VDC, 1A maximum.</li> <li>• After trap, log, and trigger events were generated by the Switch, pin 2 of the alarm port is connected to pin 3 of the alarm port.</li> </ul>

## Appendix B – Cables and Connectors

### Ethernet Cable

When connecting the Switch to another switch, a bridge or hub, a normal cable is necessary. Please review these products for matching cable pin assignment.

The following diagrams and tables show the standard RJ-45 receptacle/connector and their pin assignments.

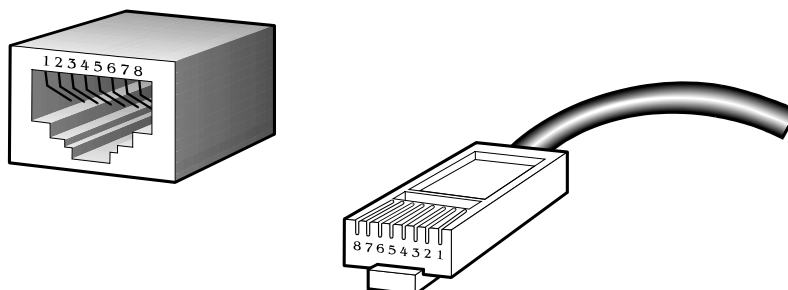
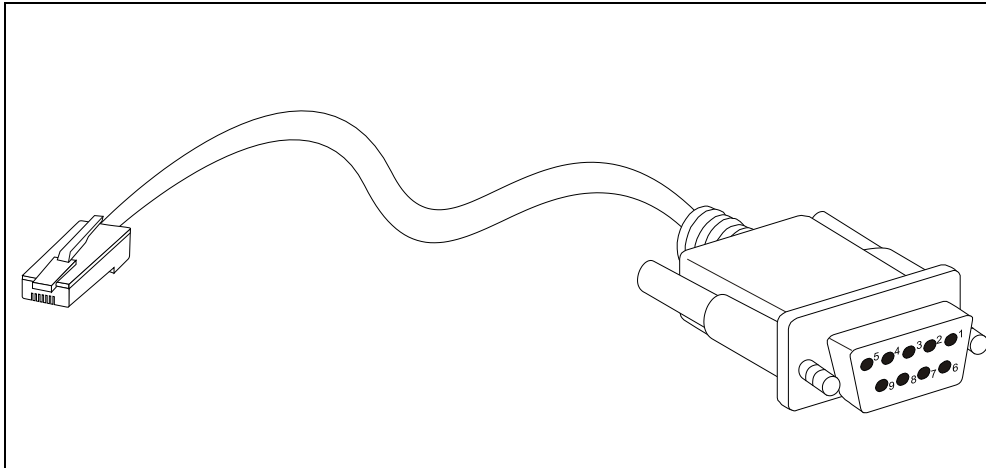

Figure B- 1. The standard RJ-45 port and connector

RJ-45 Pin Assignments		
Contact	MDI-X Port	MDI-II Port
1	RD+ (receive)	TD+ (transmit)
2	RD- (receive)	TD- (transmit)
3	TD+ (transmit)	RD+ (receive)
4	1000BASE-T	1000BASE-T
5	1000BASE-T	1000BASE-T
6	TD- (transmit)	RD- (receive)
7	1000BASE-T	1000BASE-T
8	1000BASE-T	1000BASE-T

## Console Cable

When connecting the Switch a PC, a Console cable is necessary. The following diagrams and tables show the standard Console-to-DJ-45 receptacle/connector and their pin assignments.



**Figure B- 2. Console-to-RJ-45 Cable**

Console-RJ-45 Pin Assignments		
Pin	Console (DB9/RS232)	RJ-45
1	Not Used	Not Used
2	RXD	Not Used
3	TXD	TXD
4	Not Used	GND
5	GND (shared)	GND
6	Not Used	RXD
7	Not Used	Not Used
8	Not Used	Not Used

## Redundant Power Supply (RPS) Cable

When connecting the Switch to a Redundant Power Supply, an RPS cable is necessary. Please review these products for matching cable pin assignment. The following diagrams and tables show the DPS-CB150-2PS receptacle/connector and their pin assignments.

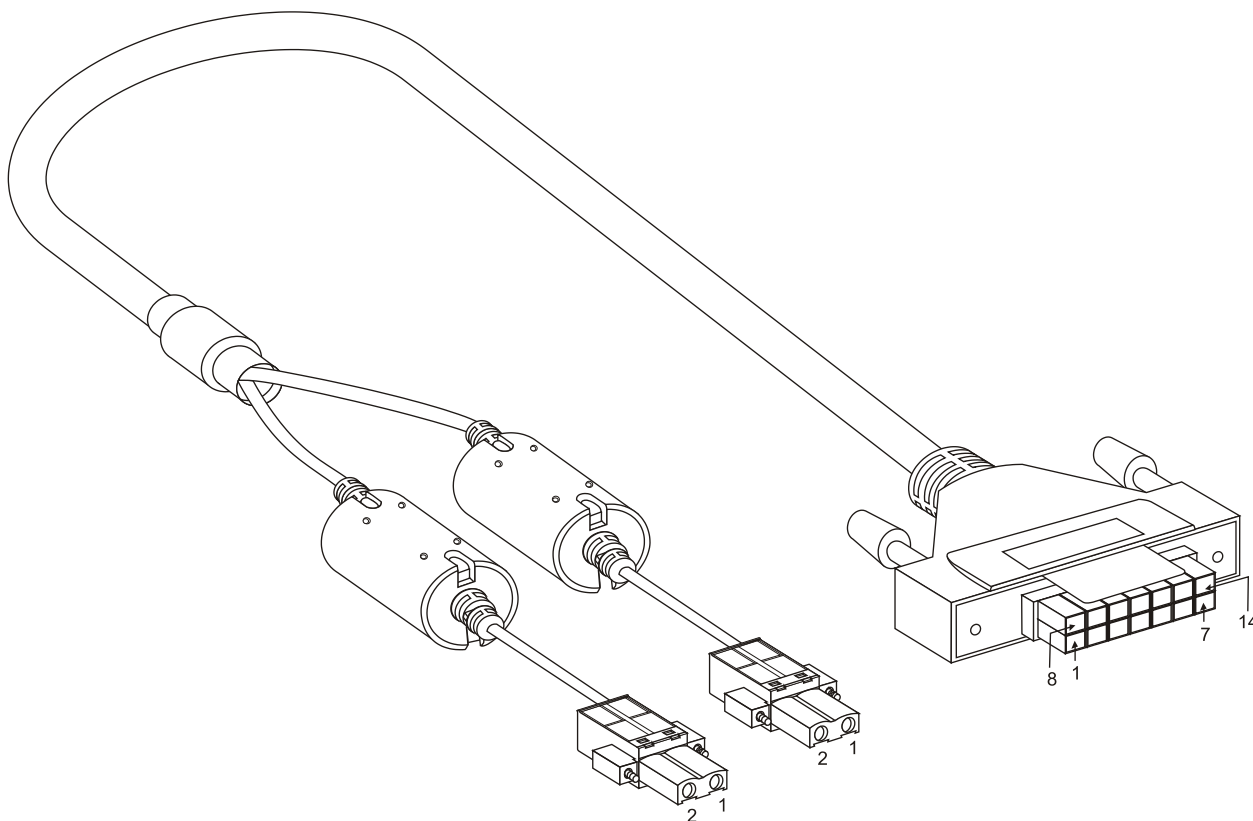

Figure B- 3. DPS-CB150-2PS Cable

RPS 14-pin to two 2-pin DC Power Cable Pin Assignments		
Pin	2-pin	14-pin
1	GND	GND
2	+12V	NC
3	-	+12V
4	-	+12V
5	-	+12V
6	-	+12V
7	-	GND
8	-	GND
9	-	Power Good
10	-	Power Present
11	-	NC
12	-	NC
13	-	GND
14	-	GND

Subject to the terms and conditions set forth herein, D-Link Systems, Inc. ("D-Link") provides this Limited Warranty:

- Only to the person or entity that originally purchased the product from D-Link or its authorized reseller or distributor, and
- Only for products purchased and delivered within the fifty states of the United States, the District of Columbia, U.S. Possessions or Protectorates, U.S. Military Installations, or addresses with an APO or FPO.

**Limited Warranty:** D-Link warrants that the hardware portion of the D-Link product described below ("Hardware") will be free from material defects in workmanship and materials under normal use from the date of original retail purchase of the product, for the period set forth below ("Warranty Period"), except as otherwise stated herein.

Limited Lifetime Warranty for the product is defined as follows:

- Hardware: For as long as the original customer/end user owns the product, or five (5) years after product discontinuance, whichever occurs first (excluding power supplies and fans)
- Power supplies and fans: Three (3) Year
- Spare parts and spare kits: Ninety (90) days

The customer's sole and exclusive remedy and the entire liability of D-Link and its suppliers under this Limited Warranty will be, at D-Link's option, to repair or replace the defective Hardware during the Warranty Period at no charge to the original owner or to refund the actual purchase price paid. Any repair or replacement will be rendered by D-Link at an Authorized D-Link Service Office. The replacement hardware need not be new or have an identical make, model or part. D-Link may, at its option, replace the defective Hardware or any part thereof with any reconditioned product that D-Link reasonably determines is substantially equivalent (or superior) in all material respects to the defective Hardware. Repaired or replacement hardware will be warranted for the remainder of the original Warranty Period or ninety (90) days, whichever is longer, and is subject to the same limitations and exclusions. If a material defect is incapable of correction, or if D-Link determines that it is not practical to repair or replace the defective Hardware, the actual price paid by the original purchaser for the defective Hardware will be refunded by D-Link upon return to D-Link of the defective Hardware. All Hardware or part thereof that is replaced by D-Link, or for which the purchase price is refunded, shall become the property of D-Link upon replacement or refund.

**Limited Software Warranty:** D-Link warrants that the software portion of the product ("Software") will substantially conform to D-Link's then current functional specifications for the Software, as set forth in the applicable documentation, from the date of original retail purchase of the Software for a period of ninety (90) days ("Software Warranty Period"), provided that the Software is properly installed on approved hardware and operated as contemplated in its documentation. D-Link further warrants that, during the Software Warranty Period, the magnetic media on which D-Link delivers the Software will be free of physical defects. The customer's sole and exclusive remedy and the entire liability of D-Link and its suppliers under this Limited Warranty will be, at D-Link's option, to replace the non-conforming Software (or defective media) with software that substantially conforms to D-Link's functional specifications for the Software or to refund the portion of the actual purchase price paid that is attributable to the Software. Except as otherwise agreed by D-Link in writing, the replacement Software is provided only to the original licensee, and is subject to the terms and conditions of the license granted by D-Link for the Software. Replacement Software will be warranted for the remainder of the original Warranty Period and is subject to the same limitations and exclusions. If a material non-conformance is incapable of correction, or if D-Link determines in its sole discretion that it is not practical to replace the non-conforming Software, the price paid by the original licensee for the non-conforming Software will be refunded by D-Link; provided that the non-conforming Software (and all copies thereof) is first returned to D-Link. The license granted respecting any Software for which a refund is given automatically terminates.

**Non-Applicability of Warranty:** The Limited Warranty provided hereunder for Hardware and Software portions of D-Link's products will not be applied to and does not cover any refurbished product and any product purchased through the inventory clearance or liquidation sale or other sales in which D-Link, the sellers, or the liquidators expressly disclaim their warranty obligation pertaining to the product and in that case, the product is being sold "As-Is" without any warranty whatsoever including, without limitation, the Limited Warranty as described herein, notwithstanding anything stated herein to the contrary.

**Submitting A Claim:** The customer shall return the product to the original purchase point based on its return policy. In case the return policy period has expired and the product is within warranty, the customer shall submit a claim to D-Link as outlined below:

- The customer must submit with the product as part of the claim a written description of the Hardware defect or Software nonconformance in sufficient detail to allow D-Link to confirm the same, along with proof of purchase of the product (such as a copy of the dated purchase invoice for the product) if the product is not registered.
- The customer must obtain a Case ID Number from D-Link Technical Support at 1-877-453-5465, who will attempt to assist the customer in resolving any suspected defects with the product. If the product is considered defective, the customer must obtain a Return Material Authorization ("RMA") number by completing the RMA form and entering the assigned Case ID Number at <https://rma.dlink.com/>.
- After an RMA number is issued, the defective product must be packaged securely in the original or other suitable shipping package to ensure that it will not be damaged in transit, and the RMA number must be prominently marked on the outside of the package. Do not include any manuals or accessories in the shipping package. D-Link will only replace the defective portion of the product and will not ship back any accessories.
- The customer is responsible for all in-bound shipping charges to D-Link. No Cash on Delivery ("COD") is allowed. Products sent COD will either be rejected by D-Link or become the property of D-Link. Products shall be fully insured by the customer and shipped to **D-Link Systems, Inc., 17595 Mt. Herrmann, Fountain Valley, CA 92708**. D-Link will not be held responsible for any packages that are lost in transit to D-Link. The repaired or replaced packages will be shipped to the customer via UPS Ground or any common carrier selected by D-Link. Return shipping charges shall be prepaid by D-Link if you use an address in the United States, otherwise we will ship the product to you freight collect. Expedited shipping is available upon request and provided shipping charges are prepaid by the customer.

D-Link may reject or return any product that is not packaged and shipped in strict compliance with the foregoing requirements, or for which an RMA number is not visible from the outside of the package. The product owner agrees to pay D-Link's reasonable handling and return shipping charges for any product that is not packaged and shipped in accordance with the foregoing requirements, or that is determined by D-Link not to be defective or non-conforming.

**What Is Not Covered:** The Limited Warranty provided herein by D-Link does not cover: Products that, in D-Link's judgment, have been subjected to abuse, accident, alteration, modification, tampering, negligence, misuse, faulty installation, lack of reasonable care, repair or service in any way that is not contemplated in the documentation for the product, or if the model or serial number has been altered, tampered with, defaced or removed; Initial installation, installation and removal of the product for repair, and shipping costs; Operational adjustments covered in the operating manual for the product, and normal maintenance; Damage that occurs in shipment, due to act of God, failures due to power surge, and cosmetic damage; Any hardware, software, firmware or other products or services provided by anyone other than D-Link; and Products that have been purchased from inventory clearance or liquidation sales or other sales in which D-Link, the sellers, or the liquidators expressly disclaim their warranty obligation pertaining to the product. While necessary maintenance or repairs on your Product can be performed by any company, we recommend that you use only an Authorized D-Link Service Office. Improper or incorrectly performed maintenance or repair voids this Limited Warranty.

**Disclaimer of Other Warranties:** EXCEPT FOR THE LIMITED WARRANTY SPECIFIED HEREIN, THE PRODUCT IS PROVIDED "AS-IS" WITHOUT ANY WARRANTY OF ANY KIND WHATSOEVER INCLUDING, WITHOUT LIMITATION, ANY WARRANTY OF MERCHANTABILITY, FITNESS FOR A PARTICULAR PURPOSE AND NON-INFRINGEMENT. IF ANY IMPLIED WARRANTY CANNOT BE DISCLAIMED IN ANY TERRITORY WHERE A PRODUCT IS SOLD, THE DURATION OF SUCH IMPLIED WARRANTY SHALL BE LIMITED TO NINETY (90) DAYS. EXCEPT AS EXPRESSLY COVERED UNDER THE LIMITED WARRANTY PROVIDED HEREIN, THE ENTIRE RISK AS TO THE QUALITY, SELECTION AND PERFORMANCE OF THE PRODUCT IS WITH THE PURCHASER OF THE PRODUCT.



**Limitation of Liability:** TO THE MAXIMUM EXTENT PERMITTED BY LAW, D-LINK IS NOT LIABLE UNDER ANY CONTRACT, NEGLIGENCE, STRICT LIABILITY OR OTHER LEGAL OR EQUITABLE THEORY FOR ANY LOSS OF USE OF THE PRODUCT, INCONVENIENCE OR DAMAGES OF ANY CHARACTER, WHETHER DIRECT, SPECIAL, INCIDENTAL OR CONSEQUENTIAL (INCLUDING, BUT NOT LIMITED TO, DAMAGES FOR LOSS OF GOODWILL, LOSS OF REVENUE OR PROFIT, WORK STOPPAGE, COMPUTER FAILURE OR MALFUNCTION, FAILURE OF OTHER EQUIPMENT OR COMPUTER PROGRAMS TO WHICH D-LINK'S PRODUCT IS CONNECTED WITH, LOSS OF INFORMATION OR DATA CONTAINED IN, STORED ON, OR INTEGRATED WITH ANY PRODUCT RETURNED TO D-LINK FOR WARRANTY SERVICE) RESULTING FROM THE USE OF THE PRODUCT, RELATING TO WARRANTY SERVICE, OR ARISING OUT OF ANY BREACH OF THIS LIMITED WARRANTY, EVEN IF D-LINK HAS BEEN ADVISED OF THE POSSIBILITY OF SUCH DAMAGES. THE SOLE REMEDY FOR A BREACH OF THE FOREGOING LIMITED WARRANTY IS REPAIR, REPLACEMENT OR REFUND OF THE DEFECTIVE OR NON-CONFORMING PRODUCT. THE MAXIMUM LIABILITY OF D-LINK UNDER THIS WARRANTY IS LIMITED TO THE PURCHASE PRICE OF THE PRODUCT COVERED BY THE WARRANTY. THE FOREGOING EXPRESS WRITTEN WARRANTIES AND REMEDIES ARE EXCLUSIVE AND ARE IN LIEU OF ANY OTHER WARRANTIES OR REMEDIES, EXPRESS, IMPLIED OR STATUTORY.

**Governing Law:** This Limited Warranty shall be governed by the laws of the State of California. Some states do not allow exclusion or limitation of incidental or consequential damages, or limitations on how long an implied warranty lasts, so the foregoing limitations and exclusions may not apply. This Limited Warranty provides specific legal rights and you may also have other rights which vary from state to state.

**Trademarks:** D-Link is a registered trademark of D-Link Systems, Inc. Other trademarks or registered trademarks are the property of their respective owners.

**Copyright Statement:** No part of this publication or documentation accompanying this product may be reproduced in any form or by any means or used to make any derivative such as translation, transformation, or adaptation without permission from D-Link Corporation/D-Link Systems, Inc., as stipulated by the United States Copyright Act of 1976 and any amendments thereto. Contents are subject to change without prior notice. Copyright 2004 by D-Link Corporation/D-Link Systems, Inc. All rights reserved.

**CE Mark Warning:** This is a Class A product. In a residential environment, this product may cause radio interference, in which case the user may be required to take adequate measures.

**FCC Statement:** This equipment has been tested and found to comply with the limits for a Class A digital device, pursuant to part 15 of the FCC Rules. These limits are designed to provide reasonable protection against harmful interference in a commercial installation. This equipment generates, uses, and can radiate radio frequency energy and, if not installed and used in accordance with the instructions, may cause harmful interference to radio communication. However, there is no guarantee that interference will not occur in a particular installation. Operation of this equipment in a residential environment is likely to cause harmful interference to radio or television reception. If this equipment does cause harmful interference to radio or television reception, which can be determined by turning the equipment off and on, the user is encouraged to try to correct the interference by one or more of the following measures:

- Reorient or relocate the receiving antenna.
- Increase the separation between the equipment and receiver.
- Connect the equipment into an outlet on a circuit different from that to which the receiver is connected.
- Consult the dealer or an experienced radio/TV technician for help.

**For detailed warranty information applicable to products purchased outside the United States, please contact the corresponding local D-Link office.**

# *Product Registration*

*Register your D-Link product online at <http://support.dlink.com/register/>  
Product registration is entirely voluntary and failure to complete or return this form will not diminish your warranty rights.*

# Tech Support

## Technical Support

You can find software updates and user documentation on the D-Link website.

D-Link provides free technical support for customers within the United States and within Canada for the duration of the service period, and warranty confirmation service, during the warranty period on this product. U.S. and Canadian customers can contact D-Link technical support through our website, or by phone.

### Tech Support for customers within the United States:

***D-Link Technical Support over the Telephone:***

USA - 877-DLINK-55 (877-354-6555)

***D-Link Technical Support over the Internet:***

<http://support.dlink.com>

### Tech Support for customers within Canada:

***D-Link Technical Support over the Telephone:***

877-354-6560

***D-Link Technical Support over the Internet:***

<http://support.dlink.com>

**D-Link®**  
Building Networks for People

## Technical Support

### United Kingdom (Mon-Fri)

Home Wireless/Broadband 0871 873 3000 (9.00am–06.00pm, Sat 10.00am-02.00pm)  
Managed, Smart, & Wireless Switches, or Firewalls 0871 873 0909 (09.00am – 05.30pm)  
(BT 10ppm, other carriers may vary.)

### Ireland (Mon-Fri)

All Products 1890 886 899 (09.00am-06.00pm, Sat 10.00am-02.00pm)  
€ 0.05ppm peak, €0.045ppm off peak Times

### Internet

<http://www.dlink.com>

## Technische Unterstützung

Deutschland:	Web:	<a href="http://www.dlink.com">http://www.dlink.com</a>
	Telefon:	+49(0)1805 2787 0,14 € pro Minute
	Zeiten:	Mo. –Fr. 09:00 – 17:30 Uhr
Österreich:	Web:	<a href="http://www.dlink.com">http://www.dlink.com</a>
	Telefon:	+43(0)820 480084 0,116 € pro Minute
	Zeiten:	Mo. –Fr. 09:00 – 17:30 Uhr
Schweiz:	Web:	<a href="http://www.dlink.com">http://www.dlink.com</a>
	Telefon:	+41(0)848 331100 0,08 CHF pro Minute
	Zeiten:	Mo. –Fr. 09:00 – 17:30 Uhr

\* Gebühren aus Mobilnetzen und von anderen Providern können abweichen.

## Assistance technique

Assistance technique D-Link sur internet : <http://www.dlink.com>

Assistance technique D-Link par téléphone : 01 76 54 84 17

Du lundi au vendredi de 9h à 19h (hors jours fériés)

## Asistencia Técnica

Asistencia Técnica Telefónica de D-Link: +34 902 30 45 45

0,067 €/min

De Lunes a Viernes de 9:00 a 19:00

<http://www.dlink.com>

## Supporto tecnico

Supporto Tecnico dal lunedì al venerdì dalle ore 9.00 alle ore 19.00 con orario continuato

Telefono: 02 87366396

<http://www.dlink.com>

## TECHNISCHE ONDERSTEUNING

Technische ondersteuning voor klanten in Nederland:

<http://www.dlink.com> / 0107994325 / €0.15per minuut.

Tech Support for customers within Belgium:

<http://www.dlink.com> / 028801640 / €0.175per minuut(spitsuren), €0.0875per minuut(daluren)

Technische ondersteuning voor klanten in Luxemburg:

<http://www.dlink.com> / +32 70 66 06 40

## Pomoc techniczna

Telefoniczna pomoc techniczna firmy D-Link: 0 801 022 021  
Pomoc techniczna firmy D-Link świadczona przez Internet:  
<http://www.dlink.com>

## Technická podpora

Web: <http://www.dlink.com>  
E-mail: [support@dlink.cz](mailto:support@dlink.cz)  
Telefon ČR: +420 211 151 640 nebo SK: +421 (0)692 147 110  
Telefonická podpora je v provozu: PO - PÁ od 09:00 do 17:00  
Volání je zpoplatněno dle příslušných tarifů Vašeho operátora.

## Technikai Támogatás

URL : <http://www.dlink.com>  
Tel. : 06 80 315-465  
Ingyenes zöld szám

## Teknisk Support

D-Link Teknisk Support over Internett: <http://www.dlink.com>  
D-Link Teknisk telefonsupport: 815 69 755  
(Hverdager 08:00 - 17:00)

## Teknisk Support

D-Link teknisk support over telefonen: Tlf.: 702 690 40  
Normale åbningstider: Hverdage kl. 08:00 - 17:00  
D-Link teknisk support på Internettet: <http://www.dlink.com>

## **Teknistä tukea asiakkaille Suomessa:**

Internetin kautta : <http://www.dlink.com>

Arkisin klo. 09:00 - 18: 00

Numerosta : 0200-555 57

## **Teknisk Support**

D-Link Teknisk Support via Internet: <http://www.dlink.com>

D-Link Teknisk Support via telefon: 0770-33 00 35

Vardagar 08:00 - 17:00

## **Assistência Técnica**

Assistência Técnica da D-Link na Internet:

<http://www.dlink.com>

e-mail: [soporte@dlink.es](mailto:soporte@dlink.es)

## **Τεχνική Υποστήριξη**

D-Link Hellas Support Center

<http://www.dlink.com>

Καλύμνου 12, 112 51, Αθήνα

Τηλ. 213 0020353 (Δευτέρα - Παρασκευή, 09.00 - 19.00)

Fax. 210 8653172

## **Tehnička podrška**

Hvala vam na odabiru D-Link proizvoda. Za dodatne informacije, podršku i upute za korištenje uređaja, molimo vas da posjetite D-Link internetsku stranicu na [www.dlink.eu](http://www.dlink.eu)  
<http://www.dlink.com>

## **Tehnična podpora**

Zahvaljujemo se vam, ker ste izbrali D-Link proizvod. Za vse nadaljnje informacije, podporo ter navodila za uporabo prosimo obiščite D-Link - ovo spletno stran [www.dlink.eu](http://www.dlink.eu)  
<http://www.dlink.com>

## **Suport tehnic**

Vă mulțumim pentru alegerea produselor D-Link. Pentru mai multe informații, suport și manuale ale produselor vă rugăm să vizitați site-ul D-Link [www.dlink.eu](http://www.dlink.eu)  
<http://www.dlink.com>



# Technical Support

You can find software updates and user documentation on the D-Link website.

## Tech Support for customers in

### Australia:

Tel: 1300-766-868  
24/7 Technical Support  
Web: <http://www.dlink.com.au>  
E-mail: [support@dlink.com.au](mailto:support@dlink.com.au)

### India:

Tel: +91-832-2856000  
Toll Free 1800-233-0000  
Web: [www.dlink.co.in](http://www.dlink.co.in)  
E-Mail: [helpdesk@dlink.co.in](mailto:helpdesk@dlink.co.in)

### Singapore, Thailand, Indonesia, Malaysia, Philippines, Vietnam:

Singapore - [www.dlink.com.sg](http://www.dlink.com.sg)  
Thailand - [www.dlink.co.th](http://www.dlink.co.th)  
Indonesia - [www.dlink.co.id](http://www.dlink.co.id)  
Malaysia - [www.dlink.com.my](http://www.dlink.com.my)  
Philippines - [www.dlink.com.ph](http://www.dlink.com.ph)  
Vietnam - [www.dlink.com.vn](http://www.dlink.com.vn)

### Korea:

Tel : +82-2-2028-1810  
Monday to Friday 9:00am to 6:00pm  
Web : <http://d-link.co.kr>  
E-mail : [g2b@d-link.co.kr](mailto:g2b@d-link.co.kr)

### New Zealand:

Tel: 0800-900-900  
24/7 Technical Support  
Web: <http://www.dlink.co.nz>  
E-mail: [support@dlink.co.nz](mailto:support@dlink.co.nz)

### South Africa and Sub Sahara Region:

Tel: +27 12 661 2065  
08600 DLINK (for South Africa only)  
Monday to Friday 8:30am to 9:00pm South Africa Time  
Web: <http://www.d-link.co.za>  
E-mail: [support@d-link.co.za](mailto:support@d-link.co.za)

### D-Link Middle East - Dubai, U.A.E.

Plot No. S31102,  
Jebel Ali Free Zone South,  
P.O.Box 18224, Dubai, U.A.E.  
Tel: +971-4-8809022  
Fax: +971-4-8809066 / 8809069  
Technical Support: +971-4-8809033  
General Inquiries: [info.me@dlinkmea.com](mailto:info.me@dlinkmea.com)  
Tech Support: [support.me@dlinkmea.com](mailto:support.me@dlinkmea.com)

### Egypt

1, Makram Ebeid Street - City Lights Building  
Nasrcity - Cairo, Egypt  
Floor 6, office C2  
Tel.: +2 02 26718375 - +2 02 26717280  
Technical Support: +2 02 26738470  
General Inquiries: [info.eg@dlinkmea.com](mailto:info.eg@dlinkmea.com)  
Tech Support: [support.eg@dlinkmea.com](mailto:support.eg@dlinkmea.com)

### Kingdom of Saudi Arabia

Office # 84 ,  
Al Khaleej Building ( Mujamathu Al-Khaleej)  
Opp. King Fahd Road, Olaya  
Riyadh - Saudi Arabia  
Tel: +966 1121 70008  
Technical Support:  
+966 1121 70009  
General Inquiries: [info.sa@dlinkmea.com](mailto:info.sa@dlinkmea.com)  
Tech Support: [support.sa@dlinkmea.com](mailto:support.sa@dlinkmea.com)

### Pakistan

Islamabad Office:  
61-A, Jinnah Avenue, Blue Area,  
Suite # 11, EBC, Saudi Pak Tower,  
Islamabad - Pakistan  
Tel.: +92-51-2800397, 2800398  
Fax: +92-51-2800399

### Karachi Office:

D-147/1, KDA Scheme # 1,  
Opposite Mudassir Park, Karsaz Road,  
Karachi – Pakistan  
Phone: +92-21-34548158, 34326649  
Fax: +92-21-4375727  
Technical Support: +92-21-34548310, 34305069  
General Inquiries: [info.pk@dlinkmea.com](mailto:info.pk@dlinkmea.com)  
Tech Support: [support.pk@dlinkmea.com](mailto:support.pk@dlinkmea.com)

## Technical Support

You can find software updates and user documentation on the D-Link website.

### Tech Support for customers in

#### Iran

Unit 5, 5th Floor, No. 20, 17th Alley , Bokharest  
St. , Argentine Sq. ,  
Tehran IRAN  
Postal Code : 1513833817  
Tel: +98-21-88880918,19  
+98-21-88706653,54  
General Inquiries: info.ir@dlinkmea.com  
Tech Support: support.ir@dlinkmea.com

#### Morocco

M.I.T.C  
Route de Nouaceur angle RS et CT 1029  
Bureau N° 312 ET 337  
Casablanca , Maroc  
Phone : +212 663 72 73 24  
Email: support.na@dlinkmea.com

#### Lebanon RMA center

Dbayeh/Lebanon  
PO Box:901589  
Tel: +961 4 54 49 71 Ext:14  
Fax: +961 4 54 49 71 Ext:12  
Email: taoun@dlinkmea.com

#### Bahrain

Technical Support: +973 1 3332904

#### Kuwait:

Technical Support: + 965 22453939 / +965  
22453949

#### Türkiye Merkez İrtibat Ofisi

Ayazağa Maslak yolu  
Erdebil Cevahir İş Merkezi No: 5/A Ayazağa /  
Maslak İstanbul  
Tel: +90 212 2895659  
Ücretsiz Müşteri Destek Hattı: 0 800 211 00 65  
Web:www.dlink.com.tr  
Teknik Destek: support.tr@dlink.com.tr

#### Israel

רח' המגשימים 20  
קרית מטלון, פ"ת 49348  
ת.ד. 7060  
טלפון: 073-796-2797  
אי-מאייל כללי: info@dlink.co.il  
אי-מאייל תמיכה: support@dlink.co.il

## Техническая поддержка

Обновления программного обеспечения и документация доступны на Интернет-сайте D-Link. D-Link предоставляет бесплатную поддержку для клиентов в течение гарантийного срока. Клиенты могут обратиться в группу технической поддержки D-Link по телефону или через Интернет.

### Техническая поддержка D-Link:

8-800-700-5465

### Техническая поддержка через Интернет:

<http://www.dlink.ru>

e-mail: [support@dlink.ru](mailto:support@dlink.ru)

## Офисы

### Россия

129626 г. Москва

Графский пер., 14

Тел.: +7 (495) 744-0099

### Украина,

04080 г. Киев, ул. Межигорская, 87-А, офис 18

Тел.: +38 (044) 545-64-40

E-mail: [kiev@dlink.ru](mailto:kiev@dlink.ru)

### Беларусь

220114, г. Минск, проспект Независимости, 169, БЦ "XXI Век"

Тел.: +375(17) 218-13-65

E-mail: [minsk@dlink.ru](mailto:minsk@dlink.ru)

### Казахстан,

050008, г. Алматы, ул. Курмангазы, 143

(уг. Муканова)

Тел./факс: +7 727 378-55-90

E-mail: [almaty@dlink.ru](mailto:almaty@dlink.ru)

### Армения

0038, г. Ереван, ул. Абеяна, 6/1, 4 этаж

Тел./Факс: + 374 (10) 398-667

E-mail: [erevan@dlink.ru](mailto:erevan@dlink.ru)

### Грузия

Тел./Факс: +995 (593) 98-3210

### Lietuva

09120, Vilnius, Žirmūnų 139-303

Tel./faks. +370 (5) 236-3629

E-mail: [info@dlink.lt](mailto:info@dlink.lt)

### Eesti

Mustamae 55-314

10621, Tallinn

Tel +372 613 9771

e-mail: [info@dlink.ee](mailto:info@dlink.ee)

### Latvija

Mazā nometņu 45/53 (ieeja no Nāras ielas)

LV-1002, Rīga

Tel.:+371 7 618-703

Fax: +371 7 618-706

e-pasts: [info@dlink.lv](mailto:info@dlink.lv)

## SOPORTE TÉCNICO

Usted puede encontrar actualizaciones de softwares o firmwares y documentación para usuarios a través de nuestro sitio [www.dlinkla.com](http://www.dlinkla.com)

### SOPORTE TÉCNICO PARA USUARIOS EN LATINO AMERICA

Soporte técnico a través de los siguientes teléfonos de D-Link

PAIS	NUMERO
Argentina	0800 - 12235465
Chile	800 260200
Colombia	01800 - 0180073
Costa Rica	0800 - 0521478
Ecuador	1800 - 035465
El Salvador	800 - 6335
Guatemala	1800 - 8350255
México	01800 - 0626270
Panamá	011 008000525465
Perú	0800 - 00968
Venezuela	0800 - 1005767

### Soporte Técnico de D-Link a través de Internet

Horario de atención Soporte Técnico en [www.dlinkla.com](http://www.dlinkla.com)

e-mail: [sosporte@dlinkla.com](mailto:sosporte@dlinkla.com) & [consultas@dlinkla.com](mailto:consultas@dlinkla.com)

**D-Link®**  
Building Networks for People

## Suporte Técnico

Caso tenha dúvidas na instalação do produto, entre em contato com o Suporte Técnico D-Link.

Acesse o site: [www.dlink.com.br/suporte](http://www.dlink.com.br/suporte)



## D-Link 友訊科技 台灣分公司 技術支援資訊

如果您還有任何本使用手冊無法協助您解決的產品相關問題，台灣地區用戶可以透過我們的網站、電子郵件或電話等方式與D-Link台灣地區技術支援工程師聯絡。

**D-Link 免付費技術諮詢專線**

0800-002-615

手機付費電話 (02)6600-0123#8715

服務時間：週一至週五，早上9:00到晚上9:00

(不含周六、日及國定假日)

網 站：<http://www.dlink.com.tw>

電子郵件：[dssqa\\_service@dlink.com.tw](mailto:dssqa_service@dlink.com.tw)

如果您是台灣地區以外的用戶，請參考D-Link網站全球各地分公司的聯絡資訊以取得相關支援服務。

產品保固期限、台灣區維修據點查詢，請參考以下網頁說明：

<http://www.dlink.com.tw>

產品維修：

使用者可直接送至全省聯強直營維修站或請洽您的原購買經銷商。

**D-Link<sup>®</sup>**  
Building Networks for People

## **Dukungan Teknis**

Update perangkat lunak dan dokumentasi pengguna dapat diperoleh pada situs web D-Link.

### **Dukungan Teknis untuk pelanggan:**

#### **Dukungan Teknis D-Link melalui telepon:**

Tel: +62-21-5731610

#### **Dukungan Teknis D-Link melalui Internet:**

Email : [support@dlink.co.id](mailto:support@dlink.co.id)

Website : <http://support.dlink.co.id>



## Technical Support

この度は弊社製品をお買い上げいただき、誠にありがとうございます。

製品に同梱されている保証書の購入元にお問い合わせください。

**D-Link**<sup>®</sup>  
Building Networks for People



## 技术支持

办公地址：北京市朝阳区将台路5号院5号楼 邮编：100016

技术支持中心电话：400-629-6688

技术支持中心传真：(028)-61317620

各地维修中心地址请登陆官方网站查询

网址：<http://www.dlink.com.cn>

400电话工作时间：工作日9:00-19:00；节假日9:00-18:00.

**D-Link**<sup>®</sup>  
Building Networks for People

# Registration Card

## All Countries and Regions Excluding USA

*Print, type or use block letters.*

Your name: Mr./Ms \_\_\_\_\_

Organization: \_\_\_\_\_ Dept. \_\_\_\_\_

Your title at organization: \_\_\_\_\_

Telephone: \_\_\_\_\_ Fax: \_\_\_\_\_

Organization's full address: \_\_\_\_\_

Country: \_\_\_\_\_

Date of purchase (Month/Day/Year): \_\_\_\_\_

Product Model	Product Serial No.	* Product installed in type of computer	* Product installed in computer serial No.

(\* Applies to adapters only)

*Product was purchased from:*

Reseller's name: \_\_\_\_\_

Telephone: \_\_\_\_\_

**Answers to the following questions help us to support your product:**

**1. Where and how will the product primarily be used?**

Home Office Travel Company Business Home Business Personal Use

**2. How many employees work at installation site?**

1 employee 2-9 10-49 50-99 100-499 500-999 1000 or more

**3. What network protocol(s) does your organization use ?**

XNS/IPX TCP/IP DECnet Others \_\_\_\_\_

**4. What network operating system(s) does your organization use ?**

D-Link LANsmart Novell NetWare NetWare Lite SCO Unix/Xenix PC NFS 3Com 3+Open Cisco Network  
Banyan Vines DECnet Pathwork Windows NT Windows 98 Windows 2000/ME Windows XP  
Others \_\_\_\_\_

**5. What network management program does your organization use ?**

D-View HP OpenView/Windows HP OpenView/Unix SunNet Manager Novell NMS  
NetView 6000 Others \_\_\_\_\_

**6. What network medium/media does your organization use ?**

Fiber-optics Thick coax Ethernet Thin coax Ethernet 10BASE-T UTP/STP  
100BASE-TX 1000BASE-T Wireless 802.11b and 802.11g wireless 802.11a Others \_\_\_\_\_

**7. What applications are used on your network?**

Desktop publishing Spreadsheet Word processing CAD/CAM  
Database management Accounting Others \_\_\_\_\_

**8. What category best describes your company?**

Aerospace Engineering Education Finance Hospital Legal Insurance/Real Estate Manufacturing  
Retail/Chain store/Wholesale Government Transportation/Utilities/Communication VAR  
System house/company Other \_\_\_\_\_

**9. Would you recommend your D-Link product to a friend?**

Yes No Don't know yet

**10. Your comments on this product?**

\_\_\_\_\_

\_\_\_\_\_

PLEASE  
PLACE STAMP  
HERE

**TO:**

---

---

---

**D-Link®**