

# Quick Reference

## Loading paper and specialty media

This section explains how to load the 550-sheet tray, an optional 2,000-sheet tray, a multipurpose feeder, and an optional 550-sheet specialty media drawer. It also includes information about paper orientation, setting the Paper Size and Paper Type, and linking and unlinking trays.

### Setting the paper size and type

The Paper Size setting is automatically sensed according to the position of the paper guides in each tray except the multipurpose feeder. The Paper Size setting for the multipurpose feeder must be set manually from the Paper Size menu. The Paper Type setting must be set manually for all trays that do not contain plain paper.

From the home screen navigate to:

 > **Paper Menu** > **Paper Size/Type** > select a tray > select the paper size or type > 

The factory default Paper Type setting is Plain Paper.

### Configuring Universal paper settings



The Universal Paper Size is a user-defined setting that lets you print on paper sizes that are not preset in the printer menus. Set the Paper Size for the specified tray to Universal when the size you want is not available from the Paper Size menu. Then, specify all of the following Universal size settings for your paper:

- Units of Measure
- Portrait Width
- Portrait Height

#### Notes:

- The largest supported Universal size is 216 x 1219 mm (8.5 x 48 in.).
- The smallest supported Universal size is 76 x 127 mm (3 x 5 in.) and loaded in the multipurpose feeder only.

From the home screen, navigate to:

 > **Paper Menu** > **Universal Setup** > **Units of Measure** > select unit of measure > **Portrait Width** or **Portrait Height** > select width or height > 

### Loading the standard or optional 550-sheet tray

The printer has one standard 550-sheet tray (Tray 1), and may have one or more optional 550-sheet trays. All 550-sheet trays support the same paper sizes and types.

- 1 Pull the tray out.

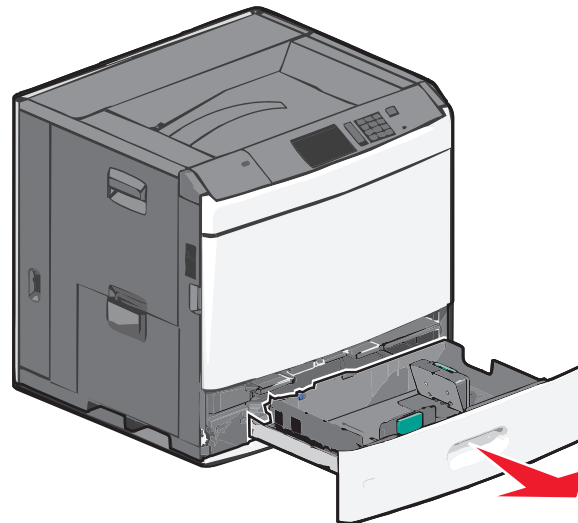

Notice the size indicators on the bottom of the tray. Use these indicators to help position the length and width guides.

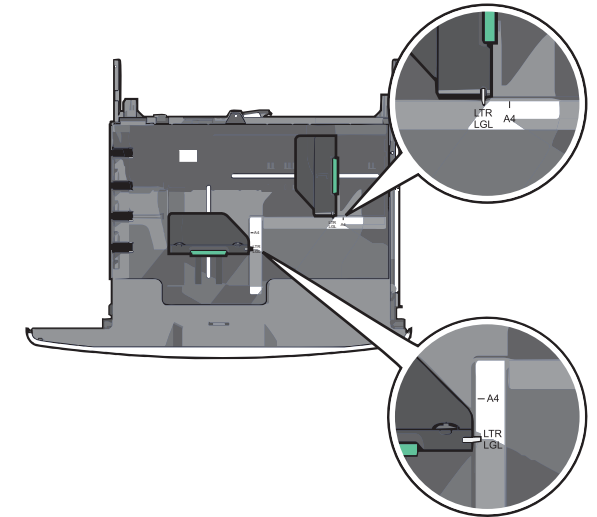

- 2 Squeeze and then slide the width guide to the correct position for the paper size you are loading.

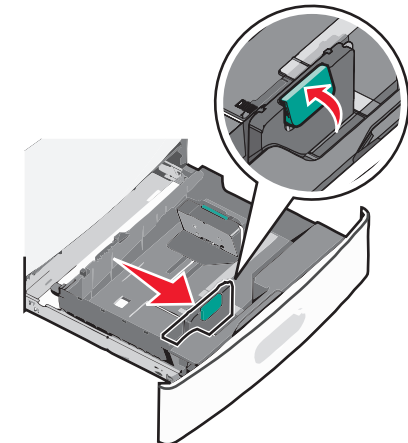

- 3 Squeeze and then slide the length guide to the correct position for the paper size you are loading.

**Note:** The length guide has a locking device. To unlock, slide the button on top of the length guide down. To lock, slide the button up when a length has been selected.

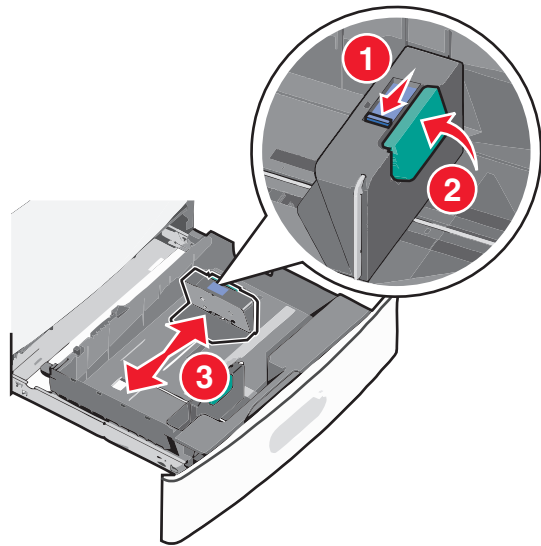

**4** Flex the sheets back and forth to loosen them. Do not fold or crease the paper. Straighten the edges on a level surface.

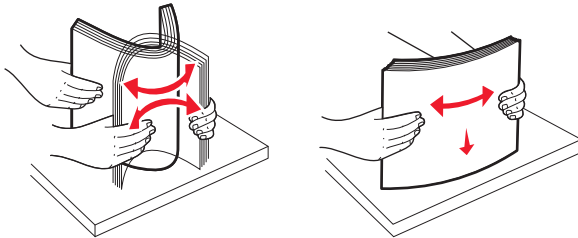

**5** Load the paper stack with the recommended print side faceup.

**Notes:**

- Place print side facedown for duplex printing.
- Place pre-punched paper with the holes toward the front of the tray.
- Place letterheads faceup with the header on the left side of the tray.
- Place letterheads facedown with the header on the right side of the tray for duplex printing.
- Make sure the paper is below the maximum fill line located on the edge of the paper tray. Overloading the tray can cause paper jams and possible printer damage.

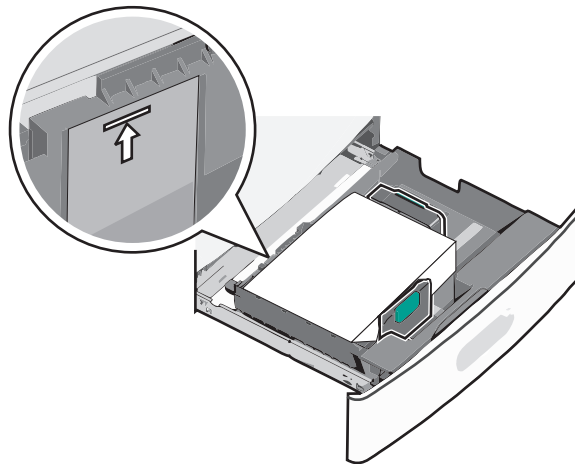

**6** Insert the tray.

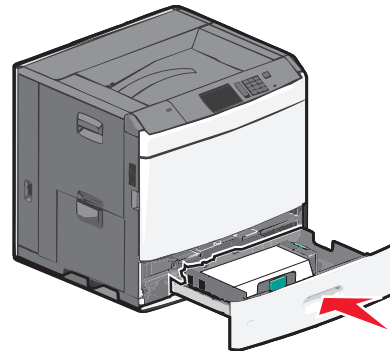

**7** From the printer control panel, verify the Paper Size and Paper Type for the tray based on the paper you loaded.

## Loading the 2000-sheet high-capacity feeder

The high-capacity feeder can hold up to 2,000 sheets of letter-, A4-, and legal-size paper (80 g/m<sup>2</sup> or 20 lb).

**1** Pull the tray out.

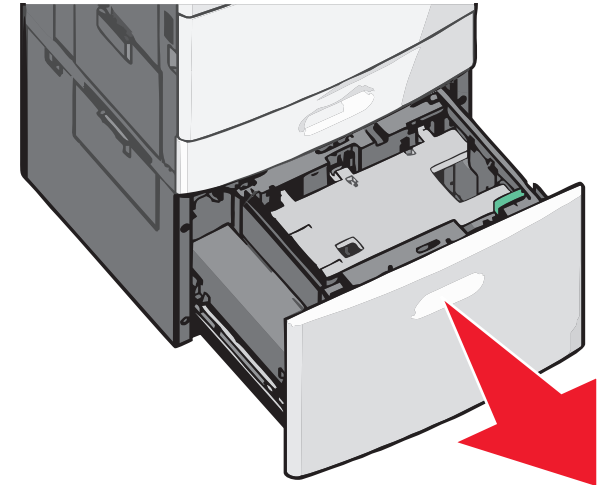

**2** Adjust the width guide as necessary.

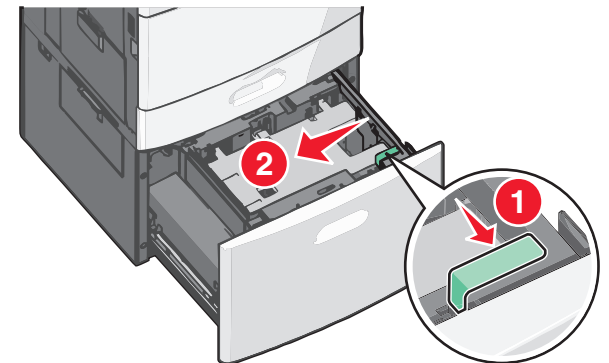

- 3 Flex the sheets back and forth to loosen them. Do not fold or crease the paper. Straighten the edges on a level surface.

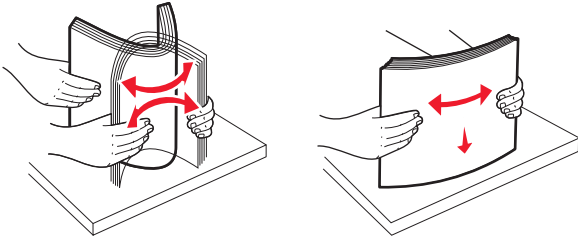

- 4 Load paper into the tray with the print side faceup.

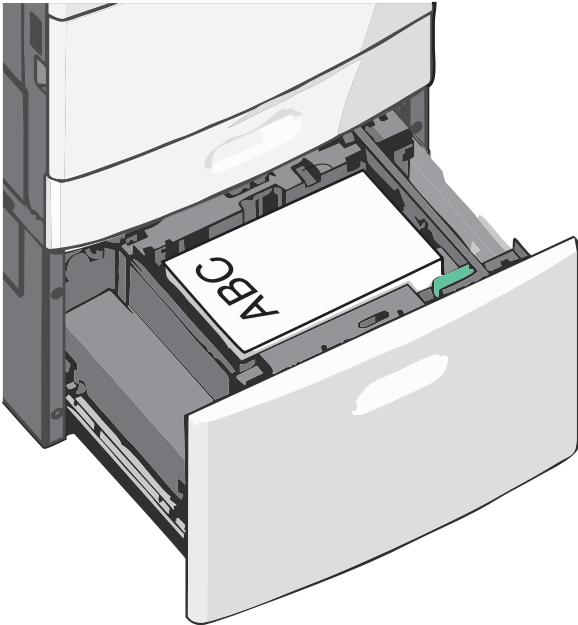

**Note:** Make sure the paper is below the maximum fill line located on the edge of the paper tray. Overloading the tray can cause paper jams and possible printer damage.

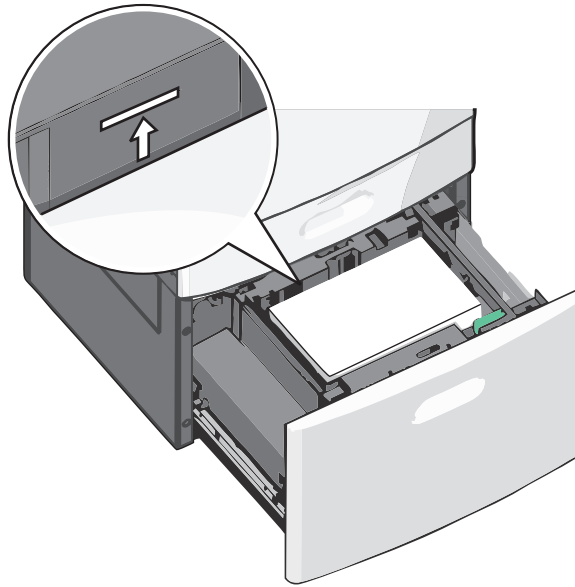

**Notes:**

- Place pre-punched paper with the holes toward the front of the tray.
- Place letterheads faceup with the header on the left side of the tray.
- Place letterheads facedown with the header on the right side of the tray for duplex printing.

- 5 Insert the tray.

## Loading the multipurpose feeder

The multipurpose feeder can hold several sizes and types of print media, such as transparencies, labels, card stock, and envelopes. It can be used for single-page or manual printing, or as an additional tray.

The multipurpose feeder can hold approximately:

- 100 sheets of 75-g/m<sup>2</sup> (20-lb) paper
- 10 envelopes
- 75 transparencies

The multipurpose feeder accepts paper or specialty media within the following dimensions:

- Width—89 mm (3.5 in.) to 229 mm (9.02 in.)
- Length—127 mm (5 in.) to 1270 mm (50 in.)

**Note:** Maximum width and length can be applied only to short-edge feeding.

**Note:** Do not add or remove paper or specialty media when the printer is printing from the multipurpose feeder or when the printer control panel indicator light is blinking. Doing so may cause a jam.

- 1 Pull down the multipurpose feeder door.

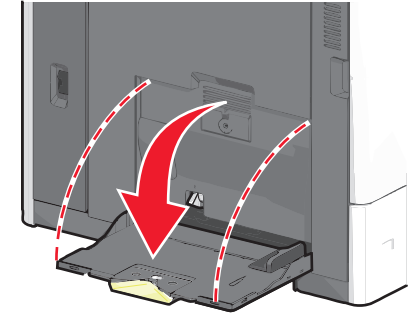

- 2 For paper or specialty media that is longer than letter-size paper, gently pull the extension until it is fully extended.

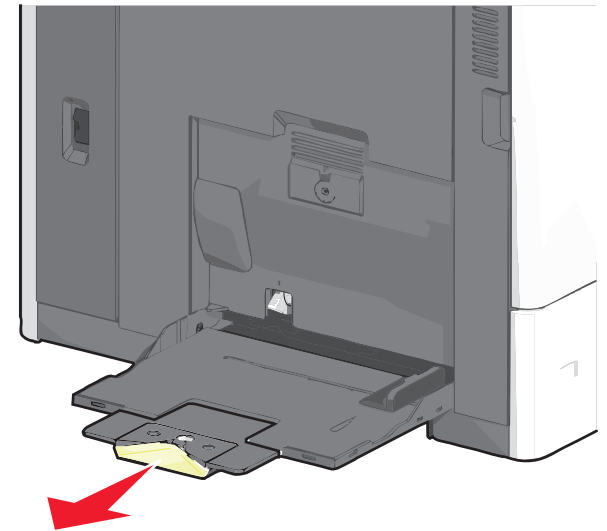

- 3 Flex the sheets of paper or specialty media back and forth to loosen them. Do not fold or crease them. Straighten the edges on a level surface.

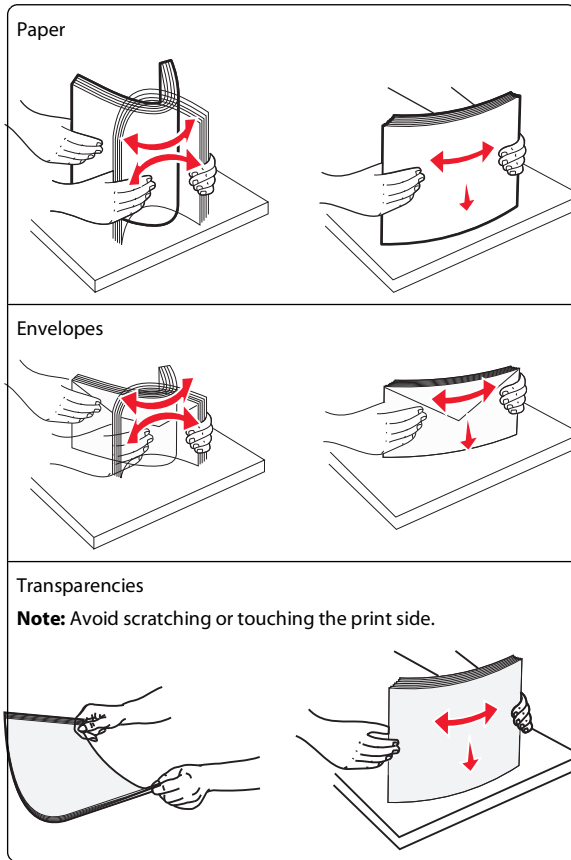

- 4 Push the paper pick tab, and then load the paper or specialty media. Slide the stack gently into the multipurpose feeder until it comes to a stop, and then release the paper pick tab.

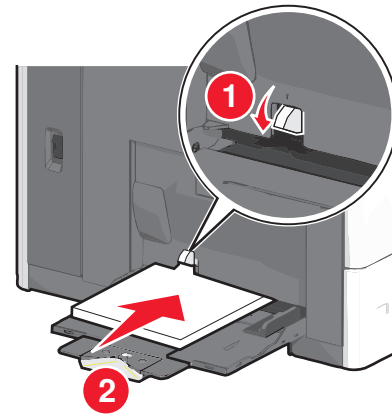

**Warning—Potential Damage:** Pulling the paper out, without pushing the paper pick tab first, may cause jams or the paper pick tab to break.

- Load paper and transparencies with the recommended print side facedown and the short edge entering the printer first.
- For duplex letterhead printing, place the letterhead faceup and the header entering the printer last.
- Load envelopes with the flap side up and to the right.

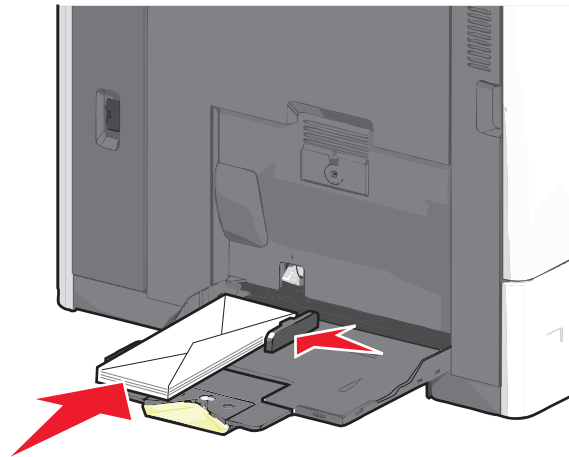

**Warning—Potential Damage:** Never use envelopes with stamps, clasps, snaps, windows, coated linings, or self-stick adhesives. These envelopes may severely damage the printer.

**Notes:**

- Do not exceed the maximum stack height by forcing paper or transparencies under the stack height limiter.
  - Load only one size and type of paper at a time.
- 5 Adjust the width guide to lightly touch the edge of the stack. Make sure the paper or specialty media fits loosely in the multipurpose feeder, lies flat, and is not bent or wrinkled.

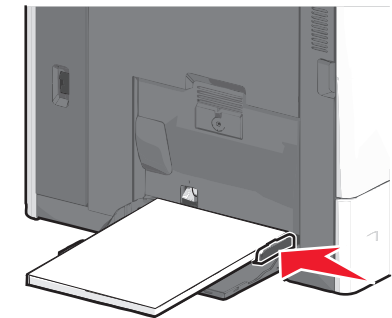

- 6 From the printer control panel, set the Paper Size and Paper Type for the multipurpose feeder (MP Feeder Size and MP Feeder Type) based on the paper or specialty media loaded.

## Linking and unlinking trays

### Linking trays

Tray linking is useful for large print jobs or for printing multiple copies. When one linked tray is empty, paper feeds from the next linked tray. When the Paper Size and Paper Type settings are the same for any trays, the trays are automatically linked. The Paper Size setting is automatically sensed according to the position of the paper guides in each tray except Tray 1 and the multipurpose feeder. The Paper Size setting for the multipurpose feeder must be set manually from the Paper Size menu. The Paper Type setting must be set for all trays from the Paper Type menu. The Paper Type menu and the Paper Size menu are both available from the Paper Size/Type menu.

### Unlinking trays

**Note:** Trays that do not have the same settings as any other tray are not linked.

Change one of the following tray settings:

- Paper Type

Paper Type names describe the paper characteristics. If the name that best describes your paper is used by linked trays, assign a different Paper Type name to the tray, such as Custom Type [x], or define your own custom name.

- Paper Size

Load a different paper size to automatically change the Paper Size setting for a tray. Paper Size settings for the multipurpose feeder are not automatic; they must be set manually from the Paper Size menu.

**Warning—Potential Damage:** Do not assign a Paper Type name that does not accurately describe the type of paper loaded in a tray. The temperature of the fuser varies according to the specified Paper Type. Prints may not be properly processed if an inaccurate Paper Type is selected.

## Linking exit bins

Link exit bins to create a single output source. The printer automatically uses the next available bin as the output source.

The standard exit bin holds up to 550 sheets of 20-lb paper. If you need additional output capacity, you can purchase other optional exit bins.

**Note:** Not all exit bins support every paper size and type.

- 1 From the home screen, navigate to:

 > Paper Menu > Bin Setup

- 2 Touch the bin or bins you want to link, and then touch **Configure Bins** > **Link**.

## Creating a custom name for a paper type

If the printer is on a network, you can use the Embedded Web Server to define a name other than Custom Type [x] for each of the custom paper types loaded into the printer.

- 1 Type the printer IP address into the address field of your Web browser.

**Note:** If you do not know the IP address of the printer, then you can:

- View the IP address on the printer control panel in the TCP/IP section under the Networks/Ports menu.
- Print a network setup page or the menu settings pages and locate the IP address in the TCP/IP section.

- 2 Click **Settings** > **Paper Menu** > **Custom Name** > type a name > **Submit**.

**Note:** This custom name will replace the Custom Type [x] name under the Custom Types and Paper Size and Type menus.

- 3 Click **Custom Types** > select a paper type > **Submit**.

## Assigning a custom paper type name

- 1 From the home screen, navigate to:

 > Paper Menu > Paper Size/Type

- 2 Select the tray number or MP Feeder Type.

- 3 Touch the left or right arrow until **Custom Type [x]** or another custom name appears.

- 4 Touch .

## Clearing jams

By carefully selecting papers and specialty media and loading it properly, you should be able to avoid most jams. For more information, see "Avoiding jams" on page 5. If jams do occur, follow the steps outlined in this chapter.

To resolve the jam messages, you must clear the entire paper path, and touch **Continue** to clear the message and resume printing. The printer prints a new copy of the page that jammed if Jam Recovery is set to On or Auto; however, the Auto setting does not guarantee the page will print.

**Note:** Jam recovery is set to Auto by default. The printer reprints jammed pages unless the memory required to hold the pages is needed for other printer tasks.

## Avoiding jams

### Paper tray recommendations

- Make sure the paper lies flat in the tray.
- Do not remove a tray while the printer is printing.
- Do not load a tray while the printer is printing. Load it prior to printing, or wait for a prompt to load it.
- Do not load too much paper. Make sure the stack height does not exceed the indicated maximum height.

- Make sure the guides in the tray or the multipurpose feeder are properly positioned and are not pressing too tightly against the paper or envelopes.
- Push the tray in firmly after loading paper.

## Paper recommendations

- Use only recommended paper or specialty media.
- Do not load wrinkled, creased, damp, bent, or curled paper.
- Flex and straighten paper before loading it.

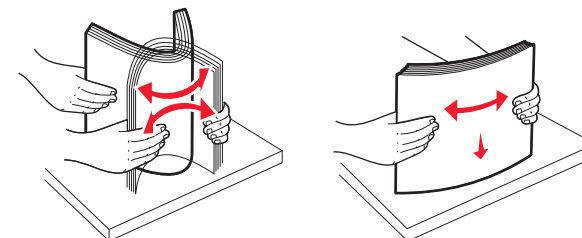

- Do not use paper that has been cut or trimmed by hand.
- Do not mix paper sizes, weights, or types in the same stack.
- Make sure all sizes and types are set correctly in the printer control panel menus.
- Store paper per manufacturer recommendations.

## Understanding jam numbers and locations

When a jam occurs, a message indicating the jam location appears on the display. To resolve any paper jam message, you must clear all jammed paper from the paper path.

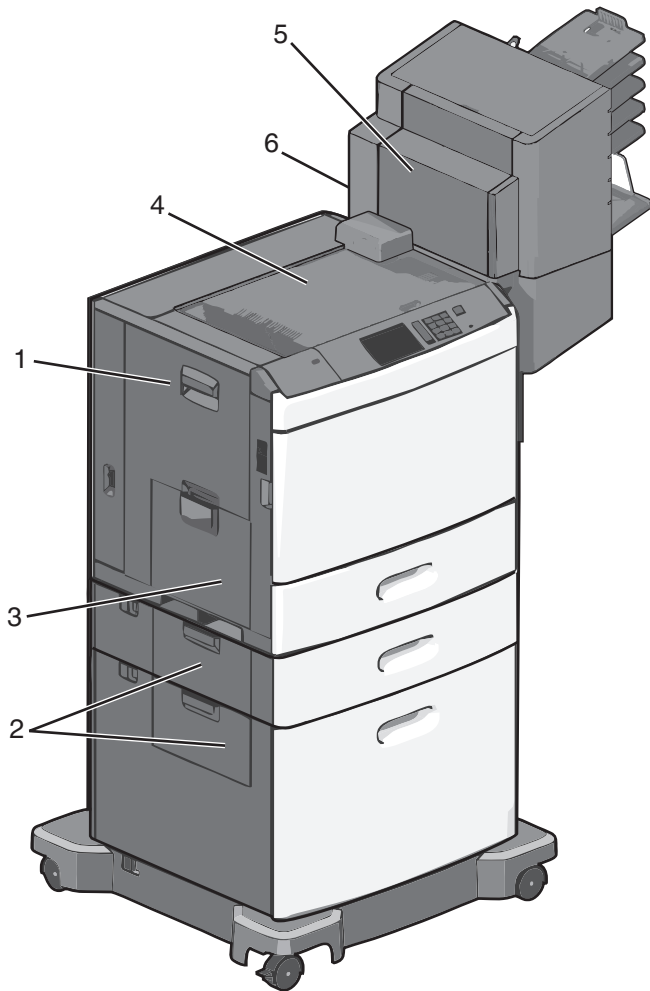

Area	Jam numbers	What to do
1	200-239	Open side door, and then remove the jammed paper.
2	24x	Open side door of the specified tray, and then remove the jammed paper.
3	250	Remove all paper from the multipurpose feeder, and then remove the jammed paper.

Area	Jam numbers	What to do
4	400-403, 460-461	Open the Horizontal Transport Unit (HTU) door, and then remove the jammed paper.
5	431-458	Push the button to slide the finisher or mailbox to the right, open the finisher or mailbox door, and then remove the jammed paper.
6	455	Open staple door, remove the staple cartridge, and then remove the jammed staple.

## 200 paper jam

- 1 Open the side door of the printer.

**CAUTION—HOT SURFACE:** The inside of the printer might be hot. To reduce the risk of injury from a hot component, allow the surface to cool before touching.

- 2 Firmly grasp the jammed paper, and then gently pull it out.

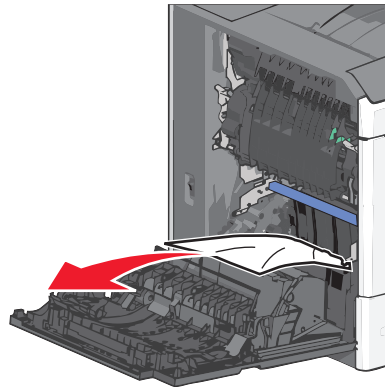

**Note:** Make sure all paper fragments are removed.

- 3 Close the side door of the printer.
- 4 From the printer control panel, touch **Continue, jam cleared**.

## 201 paper jam

- 1 Open the side door of the printer.

**CAUTION—HOT SURFACE:** The inside of the printer might be hot. To reduce the risk of injury from a hot component, allow the surface to cool before touching.

- 2 Determine where the jam is located, and then remove it:
  - a If paper is inside the fuser unit, then open the fuser access door.

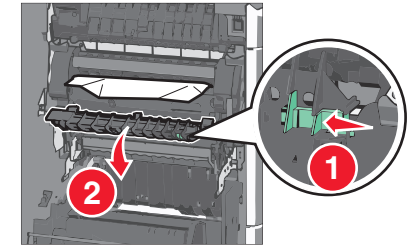

- b Firmly grasp the jammed paper on each side, and then gently pull it out.

**Warning—Potential Damage:** Do not touch the center of the fuser unit. Doing so will damage the fuser.

**Note:** Make sure all paper fragments are removed.

- 3 Close the side door of the printer.
- 4 From the printer control panel, touch **Continue, jam cleared**.

## 202–203 paper jams

If paper is visible in the standard exit bin, then firmly grasp the paper on each side, and then gently pull it out.

**Note:** Make sure all paper fragments are removed.



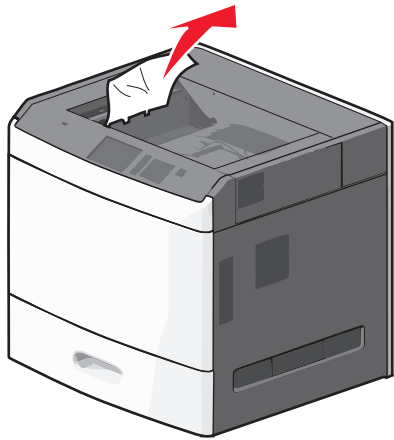

## Paper jam in the fuser

- 1 Open the side door of the printer.

**CAUTION—HOT SURFACE:** The inside of the printer might be hot. To reduce the risk of injury from a hot component, allow the surface to cool before touching.

- 2 If paper is visible inside the fuser unit, then open the fuser access door.

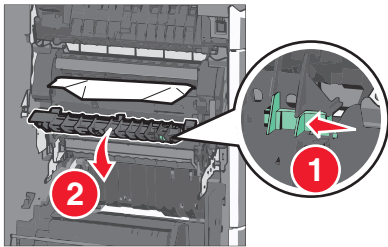

- 3 Firmly grasp the jammed paper on each side, and then gently pull it out.

**Warning—Potential Damage:** Do not touch the center of the fuser unit. Doing so will damage the fuser.

**Note:** Make sure all paper fragments are removed.

- 4 Close the side door.

## Paper jam under the fuser

- 1 Open the side door of the printer.

**CAUTION—HOT SURFACE:** The inside of the printer might be hot. To reduce the risk of injury from a hot component, allow the surface to cool before touching.

- 2 If paper is visible under the fuser, then firmly grasp the jammed paper on each side, and then gently pull it out.

**Note:** Make sure all paper fragments are removed.

- 3 Close the side door of the printer.

- 4 From the printer control panel, touch **Continue, jam cleared.**

## 230 paper jam

- 1 Open the side door of the printer.

**CAUTION—HOT SURFACE:** The inside of the printer might be hot. To reduce the risk of injury from a hot component, allow the surface to cool before touching.

- 2 Slide the latch to open the duplex cover.

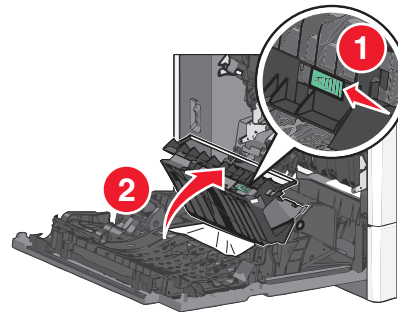

- 3 Grasp the jammed paper, and then gently pull it out.

**Note:** Make sure all paper fragments are removed.

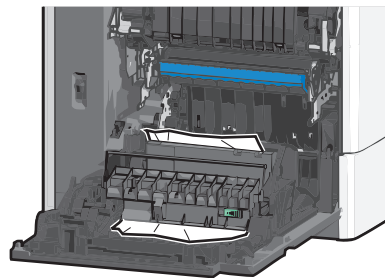

- 4 Close the duplex cover.

- 5 Close the side door of the printer.

- 6 From the printer control panel, touch **Continue, jam cleared.**

## 231–239 paper jams

- 1 Open the side door of the printer.

**CAUTION—HOT SURFACE:** The inside of the printer might be hot. To reduce the risk of injury from a hot component, allow the surface to cool before touching.

- 2 Slide the latch to open the duplex cover.

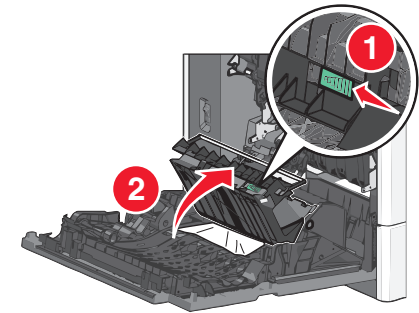

- 3 Grasp the jammed paper, and then gently pull it out.

**Note:** Make sure all paper fragments are removed.

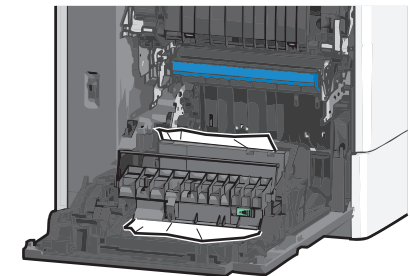

- 4 Close the duplex cover.

- 5 Close the side door of the printer.

- 6 From the printer control panel, touch **Continue, jam cleared.**

## 24x paper jam

### Paper jam in Tray 1

- 1 Open the side door.

- 2 Grasp the jammed paper on each side, and then gently pull it out.
- 3 Close the side door.
- 4 From the printer control panel, touch **Continue, jam cleared.**

## Paper jam in the optional trays

- 1 Open the side door of the specified optional tray.
- 2 Grasp the jammed paper on each side, and then gently pull it out.

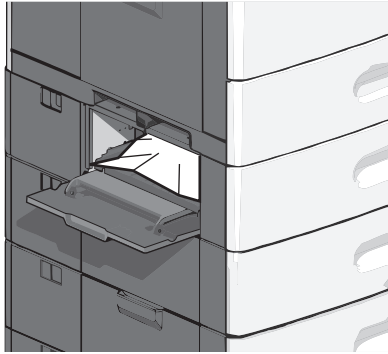

- 3 Close the side door.
- 4 From the printer control panel, touch **Continue, jam cleared.**

## 250 paper jam

- 1 Push the paper pick tab, and then remove all paper from the multipurpose feeder.

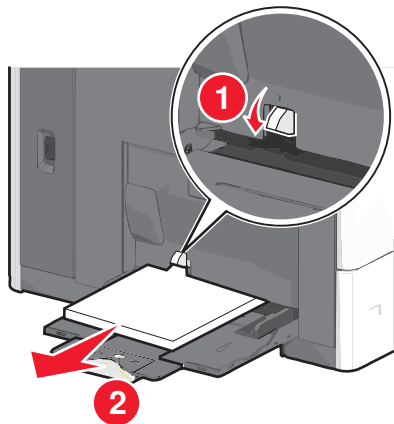

**Warning—Potential Damage:** Pulling the paper out, without pushing the paper pick tab first, may cause the paper pick tab to break.

- 2 Grasp the jammed paper on each side, and then gently pull it out.

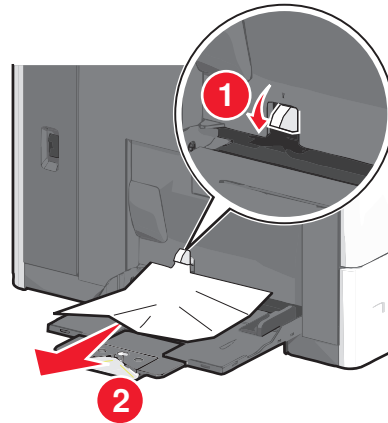

**Note:** Make sure all paper fragments are removed.

- 3 Reload paper into the multipurpose feeder, and then adjust the paper guides.
- 4 From the printer control panel, touch **Continue, jam cleared.**

## 400–403 and 460–461 paper jams

- 1 Open the paper transport unit door.

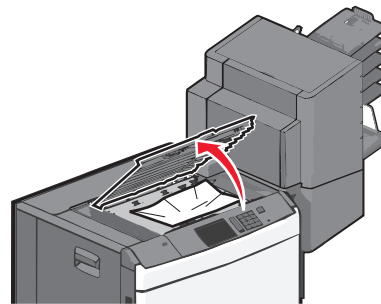

- 2 Firmly grasp the jammed paper, and then gently pull it out.

**Note:** Make sure all paper fragments are removed.

- 3 Close the paper transport unit door.
- 4 From the printer control panel, touch **Continue, jam cleared.**

## 431–454, and 456–458 paper jams

- 1 Push the button, and then slide the output finisher or mailbox to the right.

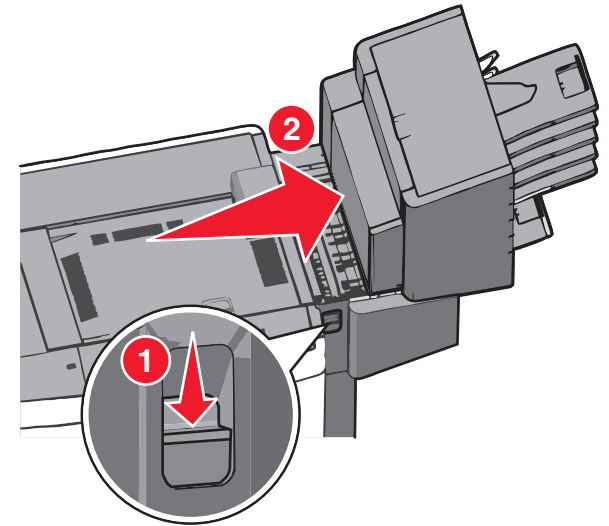

- 2 Open the finisher or mailbox access door.

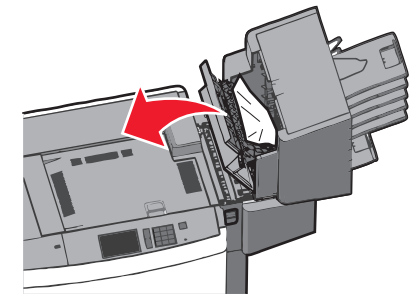

- 3 Grasp the jammed paper, and then gently pull it out.

**Note:** Make sure all paper fragments are removed.

- 4 Close the finisher or mailbox access door.
- 5 Slide the finisher or mailbox to the left until it *clicks* in place.
- 6 From the printer control panel, touch **Continue, jam cleared.**



## 455 staple jam

- 1 Press the latch to open the stapler door.

**Note:** The stapler door is located behind the finisher.

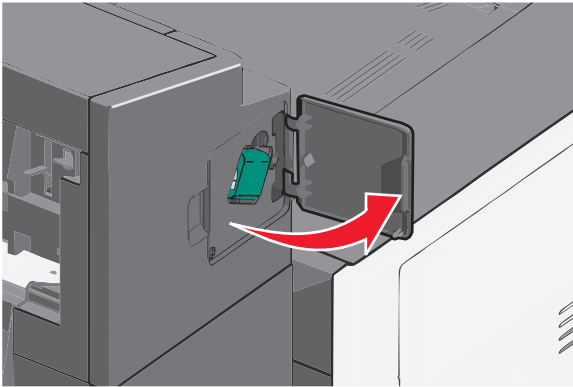

- 2 Lower the latch of the staple cartridge holder, and then pull the staple cartridge holder out of the printer.

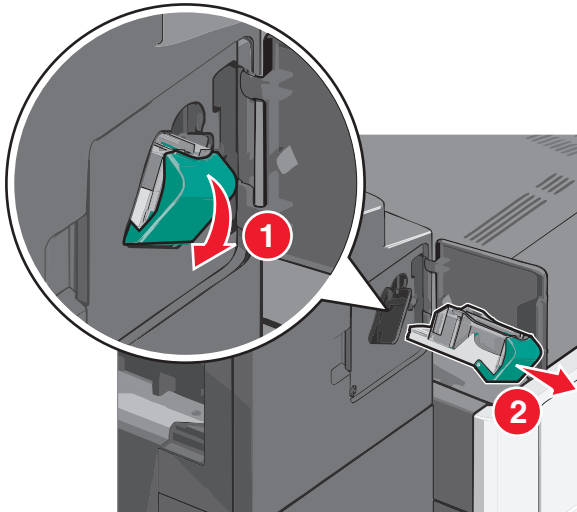

- 3 Use the metal tab to lift the staple guard, and then remove any jammed or loose staples.

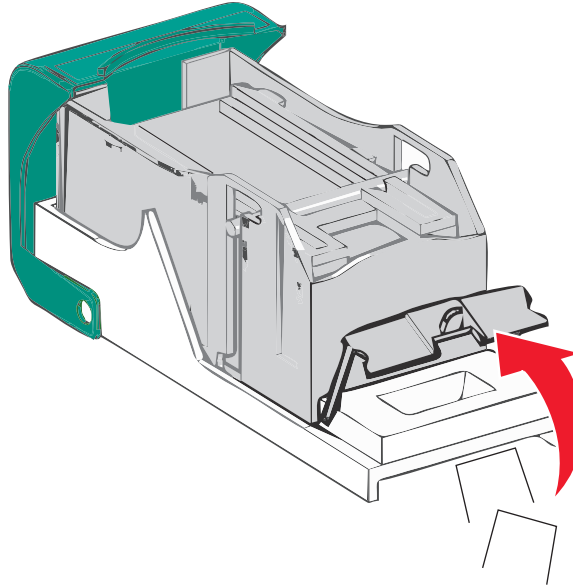

- 4 Close the staple guard.

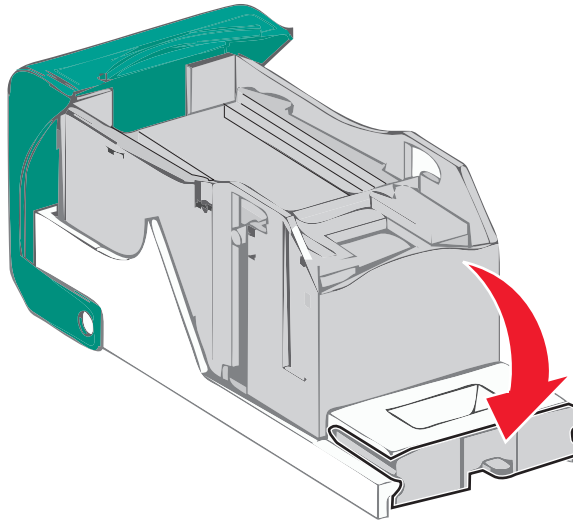

- 5 Press down on the staple guard until it *clicks* into place.

- 6 Push the staple cartridge holder firmly back into the stapler unit until the staple cartridge holder *clicks* into place.

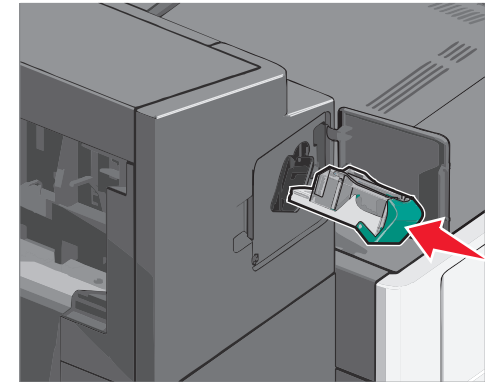

- 7 Close the stapler door.

- 8 From the printer control panel, touch **Continue, jam cleared**.

# Index

## Numerics

- 200 paper jam 6
- 2000-sheet high-capacity feeder
  - loading 2
- 201 paper jam 6
- 202–203 paper jams 6
- 230 paper jam 7
- 231–239 paper jams 7
- 24x paper jam 7
- 250 paper jam 8
- 400–403 paper jams 8
- 431–454 paper jams 8
- 455 staple jam 9
- 456–458 paper jams 8
- 460–461 paper jams 8
- 550-sheet tray (standard or optional)
  - loading 1

## A

- assigning a custom paper type name 5
- avoiding paper jams 5

## C

- card stock
  - loading in multipurpose feeder 3
- custom paper type
  - assigning 5
- custom paper type name
  - creating 5
- Custom Type [x]
  - changing name 5

## E

- envelopes
  - loading in multipurpose feeder 3
- exit bins
  - linking 5

## J

- jam locations 5
- jam numbers
  - meaning 5
- jams
  - avoiding 5
  - locating 5
- jams, clearing
  - 200 paper jam 6

- 201 paper jam 6
- 202–203 paper jams 6
- 230 paper jam 7
- 231–239 paper jams 7
- 24x paper jam 7
- 250 paper jam 8
- 400–403 paper jams 8
- 431–454 paper jams 8
- 455 staple jam 9
- 456–458 paper jams 8
- 460–461 paper jams 8

## L

- letterhead
  - loading, 2000-sheet high-capacity feeder 2
- linking
  - exit bins 5
- linking exit bins 5
- linking trays 4
- loading
  - 2000-sheet high-capacity feeder 2
  - 550-sheet tray (standard or optional) 1
  - letterhead in 2000-sheet high-capacity feeder 2
  - multipurpose feeder 3
- loading card stock
  - in multipurpose feeder 3
- loading envelopes
  - in multipurpose feeder 3
- loading the multipurpose feeder 3
- loading the standard tray 1
- loading transparencies
  - in multipurpose feeder 3

## M

- multipurpose feeder
  - loading 3

## P

- paper
  - Universal size setting 1
- paper jams
  - avoiding 5
- paper jams, clearing
  - 200 paper jam 6
  - 201 paper jam 6
  - 202–203 paper jams 6
  - 230 paper jam 7
  - 231–239 paper jams 7
  - 24x paper jam 7
  - 250 paper jam 8
  - 400–403 paper jams 8

- 431–454 paper jams 8
- 456–458 paper jams 8
- 460–461 paper jams 8
- paper size
  - setting 1
- paper type
  - setting 1

## S

- setting the paper size 1
- setting the paper type 1
- setting the Universal paper size 1
- standard tray
  - loading 1
- staple jam, clearing
  - 455 staple jam 9

## T

- transparencies
  - loading in multipurpose feeder 3
- trays
  - linking 4
  - unlinking 4

## U

- Universal Paper Size
  - setting 1
- unlinking trays 4